

Product Manual



WF-5300 SERIES PURE SINE WAVE INVERTER

WF-5318 & WF-5320



TABLE OF CONTENTS

SAFETY INFORMATION.....	1
FEATURES AND APPLICATIONS.....	2
<u>OPERATION</u>	
Control/Display Panel.....	3
Load Considerations.....	4
Inverter Run Time	5
Standby/Backup Operation.....	5
Protection Systems.....	6
Maintenance.....	7
<u>SPECIFICATIONS</u>	
Electrical Performance.....	8
Mechanical Drawings.....	9
<u>INSTALLATION</u>	
Installation Precautions.....	10
Installation Location.....	11
System Design.....	12
Wire Selection.....	14
Inverter Mounting.....	15
Control Panel Mounting.....	16
Ground Connection.....	17
Dc Connections.....	17
Ac Connections.....	19
Control Panel Connection.....	22
Testing the Inverter.....	23
Test Switch.....	23
<u>TROUBLESHOOTING</u>	
Protect Modes.....	24
No Output.....	24
Incorrect Output.....	24
WARRANTY.....	25
SERVICE.....	25

SAFETY INFORMATION WF-5300 Series Pure Sine Wave Inverter

Before operating the inverter, familiarize yourself with all safety precautions outlined in this manual. Installing or testing inverters can present a safety hazard since there can be multiple sources of high energy.

- Avoid contact with electrical terminals or exposed wiring when the inverter is operational.
- Turning the inverter off does not disconnect the batteries or ac power source. The ac output will still be active if there is any other power source, such as shore power.
- Before working on an inverter, carefully check that the inverter is NOT connected to any batteries, and that all wiring is disconnected from any electrical sources, including shore power and generator inputs.

PRECAUTIONS WHEN WORKING WITH BATTERIES

- Remove personal metal items such as rings, bracelets, necklaces, and watches when working with a battery. Batteries can produce a short-circuit current high enough to weld a ring or similar item to metal causing a severe burn.
- Be very careful when working near exposed battery terminals. Do not drop a metal tool on the battery. The resulting spark or short-circuit on the battery or other electrical part may cause a fire or explosion.
- If battery acid contacts skin or clothing, wash immediately with soap and water. If acid enters an eye, immediately wash eyes with running cold water for at least 20 minutes and get medical attention immediately.
- Never smoke or allow a spark or flame in vicinity of a lead-acid battery.

FEATURES AND APPLICATIONS

The WF-5300 series inverters convert 12-volt battery power to 115-volt ac power. They are designed with an internal transfer switch that allows the use of shore power or generator power when available, and if that power stops, the inverter can automatically and immediately start providing continuous ac power from the battery. The inverter will continue operating as long as battery power is available, or until an external source of ac power becomes available again; then it will automatically switch back. These inverters are designed for RV applications.

FEATURES

The following features make this inverter an ideal choice for applications that need this level of output power:

- 2 kW or 1.8 kW output power can easily operate most appliances when ac power is otherwise not available
- User-friendly remote control for easy and convenient operation
- Remote control displays ac and dc voltage, current, and power to allow verification and optimization of system operation
- Ruggedized design can handle the bumps from being in a vehicle or trailer
- High efficiency provides maximum run time from battery power
- Inverter can start if ac input voltage is outside of a safe range to protect appliances
- Inverter will alert and then stop if the battery voltage is out of range to avoid battery damage
- Output is protected from short circuit, overload, and over temperature to ensure safe and reliable operation
- Input is protected from reverse battery polarity to ensure safe installation
- Ac connections utilize lever connectors to help with quick, safe, and reliable installation

APPLICATIONS

In trailers, vehicles, and similar off-grid power systems, the 5300 series inverters can operate many types of 120-volt appliances such as:

- Most air conditioners
- Kitchen appliances – refrigerators, coffee makers, toasters, blenders, ice makers
- Household items – device chargers, vacuum cleaners, fans, shavers, sewing machines, fluorescent, incandescent, and LED lights.
- Entertainment electronics – televisions, video games, VCRs, stereos, sound equipment, musical instruments, satellite equipment
- Office equipment – computers, printers, monitors, scanners, facsimile machines
- Power tools – drills, circular saws, grinders, sanders, buffers, weed and hedge trimmers, air compressors

OPERATION

WF-5300 Series Pure Sine Wave Inverter

CONTROL/DISPLAY PANEL

The 5300 series inverters are operated with a control panel that is separate from the main inverter unit, which is usually installed in an electrical compartment. The control panel is typically wall mounted and allows convenient operation in or near a living area in a vehicle.

The control panel includes two pushbuttons and a display (see Figure 1). The top pushbutton (1) controls the inverter power on/off status. To turn on the inverter, press the power button for about 1 second. If it is on, and you want to turn it off, press the power button again for about 1 second.



Figure 1. Control Panel

When the inverter is on, the display will show the operational status of the power system in various ways. The graphic shows whether external ac power is present, whether the unit is in standby mode, whether it is inverting, and the battery charge level. In addition, if there is an overload or other type of fault condition, this will be shown on the display.

The lower SELECT pushbutton (2) changes the information shown with the numeric readout on the display. Initially it will show the ac output voltage in rms volts. Each time the SELECT button is pressed, the display's numeric readout will change as shown in Figure 2.

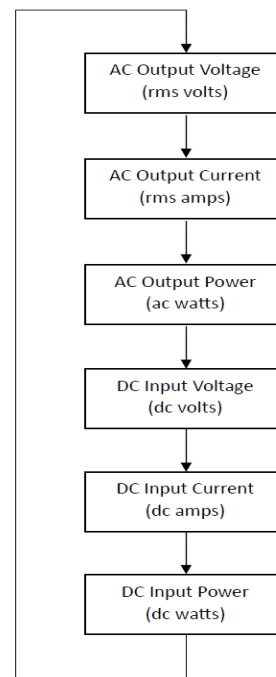

Figure 2. Display Readout Sequence

LOAD CONSIDERATIONS

When starting the inverter, it's important to consider how it will be loaded, partly because it has a certain power limit, and partly because the load directly affects how long it can operate from a given battery source. Electric heating appliances and air conditioners use a lot of power and probably can operate only one at a time, but smaller devices, such as phone chargers and small electronic devices typically use very little power and can be easily operated alongside other devices.

Figure 3 shows a list of common appliances and how much power they typically use. This is a generic estimate; for a more exact rating, look for the label on the appliance, it should indicate the specific input power rating.

Many loads, especially motor loads, will have some inrush current – they will take more than their rated current or power for a moment when initially started.

Therefore, it is best to turn these higher-power devices on first, and one at a time, rather than having everything start at once (which would happen if their power switches were already on when starting the inverter).

This will help prevent an overload condition when the inverter starts operating.

Figure 3. Typical Device Power

Appliance	Power Use Range (watts)	Typical Power (watts)
Air Conditioner RV Rooftop 13,500 BTU		1325
Air Conditioner RV Rooftop 15,000 BTU		1484
Blender		300
CD player		7
Clock Radio		2
Computer - Desktop & Monitor	200-500	250
Computer - Inkjet Printer	30-50	40
Computer - Laptop	30-70	60
Crock Pot	230	230
Curling Iron / Straightener	300-800	550
DVD player		16
Electric Blanket	50-500	275
Electric Coffee Pot	550-750	650
Electric Frying Pan/Wok	1000-1500	1250
Electric Iron	500-1500	1000
Electric Water Heater (6 gallon)	1000-1500	1250
Fan	40-300	170
Food Processor	720	720
Hair Dryer	500-1500	1000
Hand Vacuum	240	240
Microwave Oven	900-1600	1600
Mini Lights (LED type, 100 lights)		7
Phone Charger		5
Popcorn Popper	800-1400	1000
Radio	2-8	5
Refrigerator (RV)	120-300	200
Shaver (Electric)	5-10	6
Space Heater	750-1500	1500
Television 40 Inch LCD		100
Television 40 Inch LED		50
Toaster	1200	1200
Vacuum	200-1100	650
Waffle Iron	800-2000	900
Washer/Dryer	700-1900	1300

Red indicates starting power will be higher.

INVERTER RUN TIME

The amount of time the inverter can operate before the battery is expended depends on the loads and the battery (or battery bank) capacity. Figure 4 can be helpful to estimate this based on the battery capacity and load conditions.

Approximate Continuous Run Time vs. Power Usage From 12-volt Battery

Total Load Power Watts	Run Time using 30Ah of Battery		Run Time using 90 Ah of Battery		Run Time using 180 Ah of Battery	
0 (idle)	20.0	hours	50.0	hours	120.0	hours
100	2.9	hours	8.7	hours	17.5	hours
250	1.3	hours	3.8	hours	7.6	hours
500	39	minutes	1.9	hours	3.9	hours
1000	19	minutes	58	minutes	1.9	hours
1500	13	minutes	38	minutes	1.3	hours

Figure 4. Approximate continuous load run time.

In this chart, three types of battery setups with different capacities are shown; 30 Ah is typical for one lead-acid group 27 battery taken down to 50%, 90 Ah is typical for one lithium group 31 battery taken down to 10%, and 180 Ah is typical for two lithium group 31 batteries taken down to 10%. This can be used as a reference to estimate the relative time available with different battery capacities. The efficiency is about 90% at mid power levels (it will be lower when under 200 watts). The exact run time is:

$$\text{Run Time in hours} = \frac{(\text{Battery Capacity in amp-hours}) \times (12 \text{ volts}) \times (\text{efficiency})}{(\text{Total Power Draw in watts})}$$

STANDBY/BACKUP OPERATION

If the inverter is started while external ac power is present (from shore power, generator, etc.), or if external ac power starts while the inverter is operating, then it will go into standby mode. When in standby, the inverter will be ready to operate if the external ac source stops. If shore power is disconnected, or if the generator stops, then the inverter will immediately provide output voltage so that the connected appliances will continue operating uninterrupted. During standby, the inverter will use idle power, but this should be supplied by your converter/charger without affecting the battery.

PROTECTION SYSTEMS

The WF-5318 and WF-5320 inverters include protection features that ensure safe operation and recovery from a wide range of fault conditions.

When a protection feature is activated, the inverter will sound an audible alarm to indicate that output power has stopped. In the case of the battery voltage approaching its limit, the alarm will provide a warning sound before the power actually stops. Fault alarms may continue for up to one minute.

Overload

If too much current or too much power is drawn by the load on the inverter, it will stop. The design includes considerable margin for providing momentary inrush current to start motors or other difficult loads. But if the overload continues for a longer time (which depends on the amount of overload), then the unit will stop to prevent equipment damage. The remedy is to reduce the load on the inverter, so that it can operate. After 40 seconds, the inverter will automatically attempt to restart. You can also turn the inverter off and on to restart it sooner.

Under or Over Voltage at Input

If the battery input voltage drops below 11 volts, the alarm will sound to warn of a low battery voltage. If the voltage drops below 10 volts, then the inverter will stop.

If the battery input voltage is above 15 volts, the alarm will sound to warn of a high battery voltage. The inverter will stop if the input is above 16 volts.

Over Temperature

An excessively high temperature inside the inverter will cause the inverter to stop. When the unit cools down, it will restart once. If overheating persists after that, it will remain off. If it is cool enough, manually cycling the power switch can restart operation.

Short Circuit

A short circuit on the ac output – that is, if the line and neutral output are accidentally connected together – will cause the inverter to stop. After the problem is corrected, the inverter can be restarted.

Dc Reverse Polarity

Be very careful when connecting a battery to the dc system. It is usually very critical that the polarity is correct because some equipment may be permanently damaged if the polarity is

reversed. However, the WF-5318 and WF-5320 will survive that; the inverter simply will not operate. When the polarity is corrected, the inverter will function normally.

Ac Circuit Breaker

The ac output circuit is protected by a 30-amp auto-resettable circuit breaker. If excessive current is drawn at the output (including when in pass-through mode), the breaker may open the circuit. If that happens, the circuit breaker will automatically reset within one minute.

MAINTENANCE

To ensure years of reliable performance, it's a good idea to periodically check the following:

- Make sure the inverter is clean. Turn off all sources of ac power including the inverter, and then clean the exterior of the inverter with a slightly-damp cloth to prevent accumulation of dust and dirt.
- Make sure the vents and fan openings are not clogged.
- Inspect the wiring and terminations; make sure the connections are tight and all wiring and insulation is in good condition. Check for any discoloration of conductors or insulation, melted plastic, or other sign of heat. Evidence of excessive heat usually indicates a loose or corroded connection; this needs to be corrected immediately.

SPECIFICATIONS

MODEL	WF-5318	WF-5320
Inverter		
Waveform	Sine Wave	
Output Voltage	115 V ac $\pm 3\%$	
Output Current	15.7 A	17.4 A
Continuous Output Power	1800 W	2000 W
Surge Power, 2 sec.	3600 W	4000 W
Output Frequency	60 Hz ± 0.3 Hz	
Output THD, resistive load	$< 4\%$	
Input Voltage Range	10.0 - 16.0 V dc	
Input Current (no load), 12 Vdc input	< 1.6 amps	
Input Current (full load), 12 Vdc input	180 A	200 A
Peak Efficiency	$> 90\%$	
Transfer Switch		
Transfer Time	< 20 ms	
Ac Pass-Through Rating	30 amp, 24.8 amp continuous	
Switch to Shore Power	> 80 Vac or < 130 Vac	
Switch to Inverter	< 90 Vac or > 140 Vac	
Remote Control Panel		
Control Functions	Inverter Start/Stop Display Select	
Display Functions	Ac Output Voltage, Current, Power Dc Input Voltage, Current, Power Ac Input/Standby/Invert Status Protect/Fault Diagnostics	
Protection		
Output Circuit Breaker	30 A	
Overload	Auto shutdown, auto recovery	
Short Circuit	Auto shutdown	
Over Temperature	Auto shutdown, one auto recovery during operation	
Battery Reverse Polarity	No damage	
Safety Listing	UL 458	
Connectors		
Dc Input	Bolts for Ring Lugs Size M8/1.25, 13mm hex nuts	
Ac Input and Output	Lever connectors for up to 10 AWG wire	
Ground	Screw Clamp for up to 2 AWG wire	
Remote Control Panel Connector Type	6P6C (RJ-25)	
Remote Control Panel Cable Length	20 ft (6 m)	30 ft (9 m)
Mechanical/Environment		
Dimensions (LxWxH)	12.3 (13.6) x 9.5 (10.7) x 4 inches	
Weight	11.5 lb	
Cooling	Allow at least 2 cubic feet of air around unit with 3 inches of space at each end for air flow.	
Unit Installation	Bottom or side panel facing downward	
Operating Environment	14 °F to 104 °F and 20% to 90% RH Non-condensing	

MECHANICAL DRAWINGS

Figure 5. Control Panel Dimen-

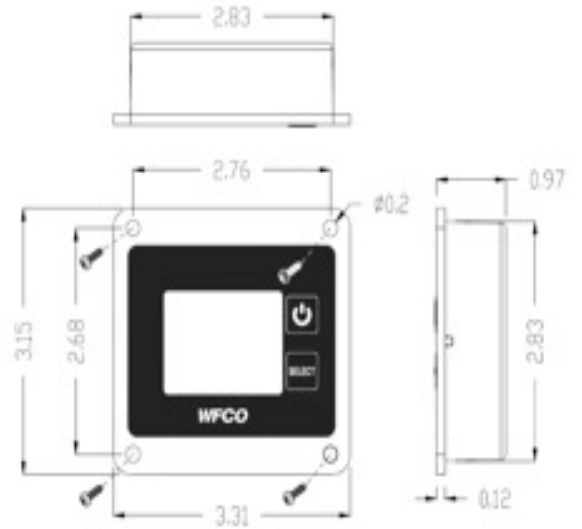
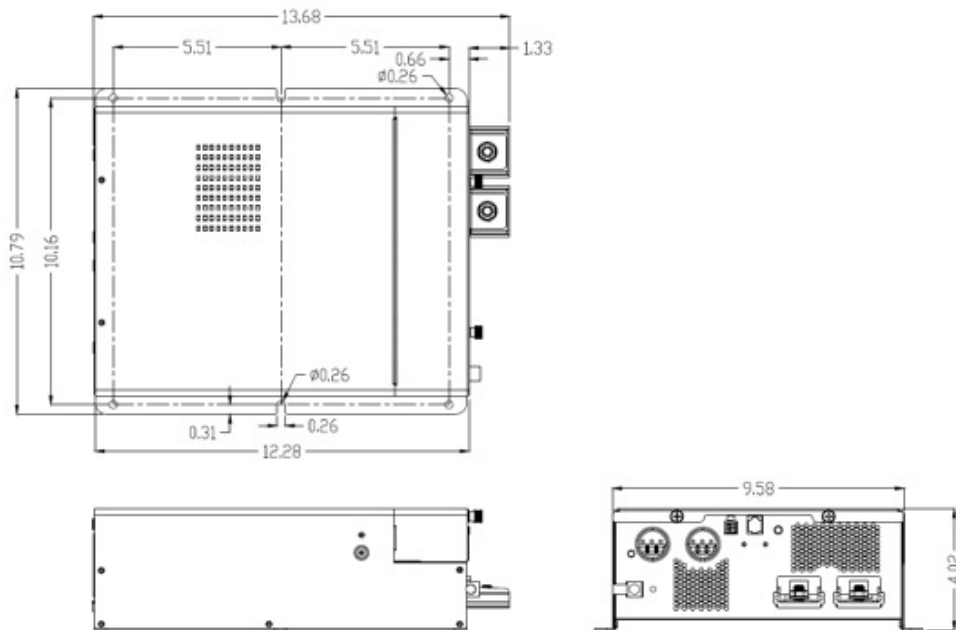

Figure 6. Inverter Dimensions



INSTALLATION: WF-5300 Series Pure Sine Wave Inverter

CAUTION!

The electrical installation must conform to the local electrical codes and should be carried out by a certified technician. The safe installation of an inverter requires some knowledge and skill. Only a qualified technician should perform this electrical work.



WARNING

Turning the inverter off does not disconnect the batteries or ac power source. Therefore, the ac output will still be active if there is any other power source, such as shore power, generator, etc.



WARNING

Shock Hazard. Before proceeding further, carefully check that the inverter is NOT connected to any batteries, and that all wiring is disconnected from any electrical sources such as shore power, generator, etc. Do not connect the output terminals of the inverter to an incoming AC source.

INSTALLATION PRECAUTIONS

- Always turn off or disconnect all power sources (ac and dc) before working on any of the wiring. Do not restore power until the wiring is complete and fully inspected.
- Be very careful about polarity and correct wiring terminations. Be sure to check the wire colors and make sure they are connected correctly. If there is any doubt about wire colors or connections, check the connections at the other end of the wire and make sure it is connected as expected. For dc circuits, the wiring polarity is critical to avoid damage. With ac circuits, the line, neutral, and ground must each be connected to its intended terminal to avoid a very dangerous result.
- Do not expose the Inverter to rain, snow, spray, bilge, or dust. To reduce risk of hazard, do not cover or obstruct the ventilation openings. To avoid overheating, do not install the inverter in a zero-clearance compartment.
- To avoid the risk of fire and electric shock, please make sure that existing wiring is in good electrical condition; and that wire size is not undersized. Do not operate the Inverter with damaged or substandard wiring.
- This equipment contains components which can produce arcs or sparks.
- To prevent fire or explosion do not install in compartments containing vented batteries or flammable materials or in locations which require ignition protected equipment. This includes any space containing gasoline-powered machinery, fuel tanks, joints, fittings, or other connection between components of the fuel system.
- Separate over-current protection for the AC output circuit shall be provided as necessary.

 **WARNING**

Operating the inverter without a proper ground connection may cause an electrical safety hazard. An 8 AWG or larger ground wire is required to connect the inverter ground to the chassis.

INSTALLATION GUIDELINES

- Please determine the remote control panel cable route throughout the vehicle, both to and from the inverter before connecting any wires.
- Always check for existing electrical, plumbing, or other areas of potential damage before drilling or cutting into walls to mount the control panel.
- Make sure all wires have a smooth bend radius and do not become kinked. The allowable bend radius depends on the type of cable and wire gauge.
- Please ensure that all conductors passing through walls, bulkheads, or other structural members are protected. This minimizes insulation damage such as chafing, which can be caused by vibration or constant rubbing when installing in a vehicle.

INSTALLATION LOCATION

The power inverter should be installed in a location that meets the following requirements:

- Dry – Do not allow water to drip or splash on the inverter.
- Cool – Ambient air temperature should be between -20°C and 40°C , but the cooler the better.
- Safety – Do not install inverter with lead-acid batteries in the compartment, or other areas near flammable fumes such as fuel storage areas or engine compartments.
- Ventilated – Allow at least one cubic foot of clearance around the Inverter for air flow. Ensure the vents on the ends and top of the unit are not obstructed.
- Dust-free – Do not install the Inverter in environments where dust, wood particles, or other filings or shavings are present. The dust can be pulled into the unit when the cooling fan is in operation.
- Close to batteries – Avoid excessive cable lengths but do not install the inverter in the same compartment as lead-acid batteries.
- Do not mount the inverter where it is exposed to the gases produced by a lead-acid battery. These gases are very corrosive and prolonged exposure will damage the inverter.
- Use the recommended wire lengths and sizes in accordance with this manual and the relevant electrical codes.

SYSTEM DESIGN

Before installing an inverter system, it's important to plan the design and procure the necessary tools and materials. In addition to the inverter, batteries, appropriate wire, wire terminals, fuses or circuit breakers, and possibly other accessories will be needed.

Figure 7. Typical Installation for RV.

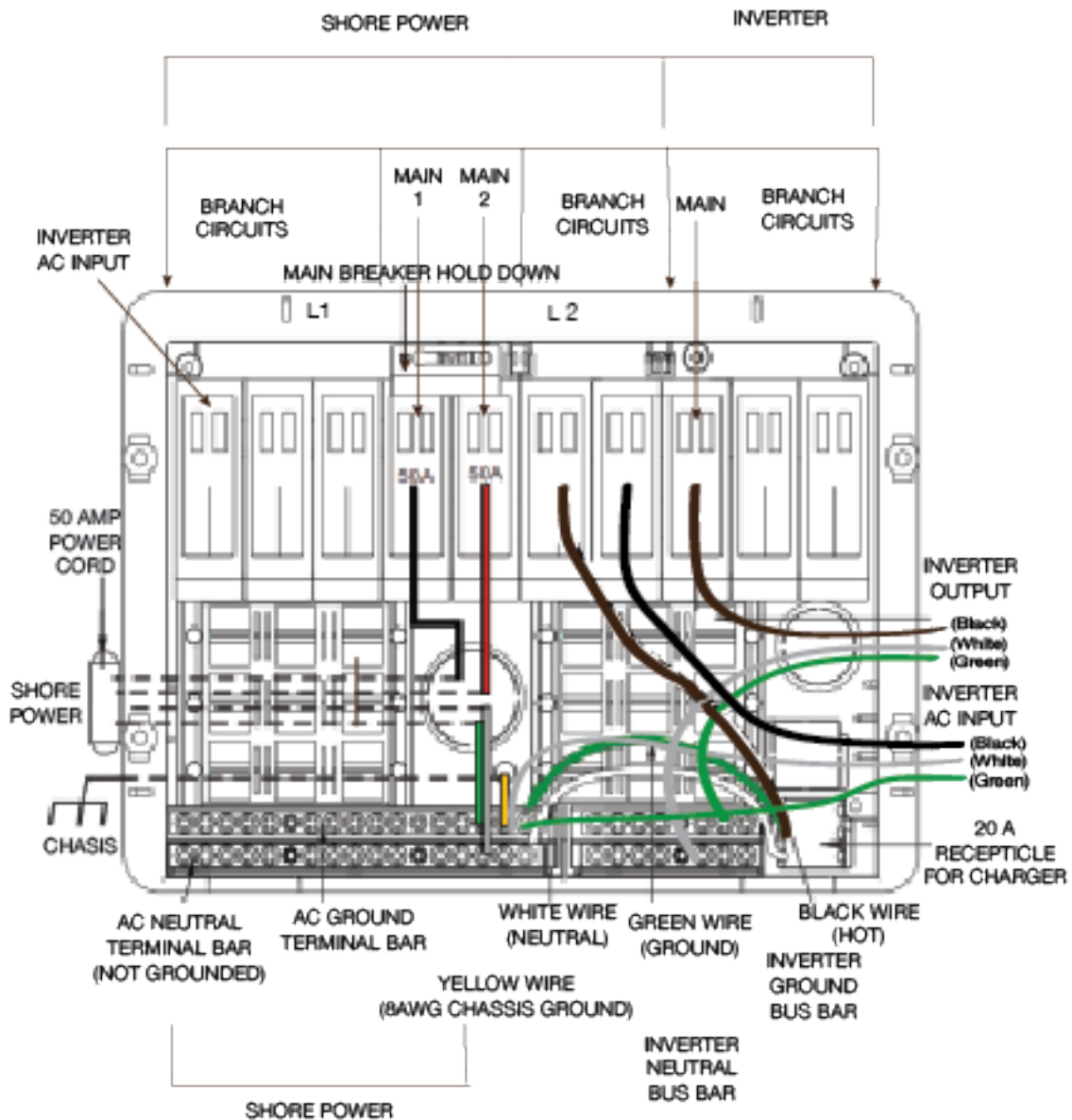

Ac Power Distribution Panel

Branch rated over current protection for the AC output circuit is to be provided at the time of installation.

A branch circuit at the ac power distribution panel can be used to supply the ac input to the inverter for bypass operation. This circuit should use a 15-amp or 20-amp circuit breaker. The ac output from the inverter can feed a separate section in the same panel, such as the WF-7923-S or WF-7925-S, to supply multiple circuits that can be powered by the inverter. Alternatively, a second panel can be used for the inverter-powered circuit distribution, if more than one circuit is to be powered by the inverter. Refer to Figure 6 for a wiring example.

The wire gauge needed for the ac wiring should follow NEC requirements for ampacity and circuit protection. Strain relief should be provided near the inverter for the ac cables.

MANUFACTURER	MODEL NUMBER
Hubbell	GFRST20W
Leviton	GFWR2-W
Cooper Wiring Devices	TRSGF20
Pass & Seymour, Inc.	BGFCI-20
Guangzhou Bosslyn	BGFCI-20

Figure 8. Allowable GFCI Devices

WIRE SELECTION

The wiring in an electrical system is important both for safety and for proper operation. The wiring needs to conform to the NEC (National Electrical Code) in the U.S.A. and any other regional or local codes or electrical regulations. If there is uncertainty about this, be sure to check the codes that apply to your installation.

The main considerations are:

- **Wire Gauge for Ampacity**

To prevent a fire, the wire must be capable of handling the maximum possible current without overheating.

- **Wire Gauge for Voltage Drop**

The wire needs to have a low enough resistance to avoid excessive voltage drop across its entire length.

- **Stranded or Solid Conductors**

Solid copper wire conductors can be used if the wire is not going to move; for permanent ac wiring this is okay. For the battery cables and dc wiring, stranded conductors are usually preferable due to flexibility and ease of installation with the typically heavier gauge wire that is used. In some cases, stranded may be needed if the wires are bundled.

- **Insulation Rating**

The wire's insulation must have the correct type, voltage rating, and temperature rating for the application.

Circuit Protection

Each electrical wire in a vehicle or trailer must be protected by a fuse or circuit breaker that will open before the wire can overheat. The current rating of the fuse or circuit breaker should not be higher than the ampacity of the wire.

Ground

The inverter needs to be grounded to the vehicle chassis. The electrical code requires that an 8 AWG wire is used for this, since it needs to be able to open the main circuit breaker in case of a short circuit to ground. See the Inverter Ground Connection section on page 24.

INVERTER LOCATION AND MOUNTING

In addition to being as close to the battery or batteries as possible, with lead-acid batteries being in a separately ventilated compartment, the WF-5318 and WF-5320 can be mounted to a horizontal deck or vertical wall. Mounting flanges are provided on each side and they can accommodate 1/4" bolts for mounting to a deck or wall. Vent openings (the ends or top) should not be oriented downward. See Figure 8 for the mounting orientation.

In addition, for proper air cooling, there should be at least 2 cubic feet of air around the inverter and at least three inches of space at each end.

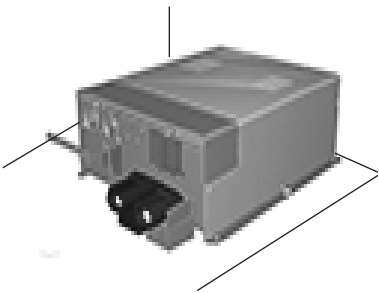

CORRECT

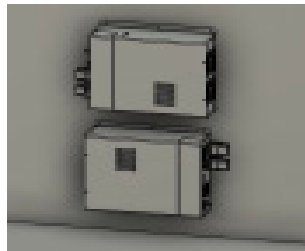

CORRECT

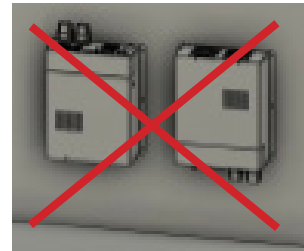

INCORRECT

Figure 9. Inverter wall mounting orientation. Horizontal is okay, vertical is not.

CONTROL PANEL LOCATION AND MOUNTING

The control panel is designed to be mounted in a wall; it can be positioned in any convenient location that can be reached from the inverter by its cable. The included cable is 20 feet (6 m) or 30 feet (9 m) long, depending on the model. The cutout for mounting the control panel can be made with a 2-7/8" diameter hole saw. The panel is secured to the wall with four #10 or #12 screws. See Figure 6 for control panel dimensions and Figure 9 for the mounting cutout pattern

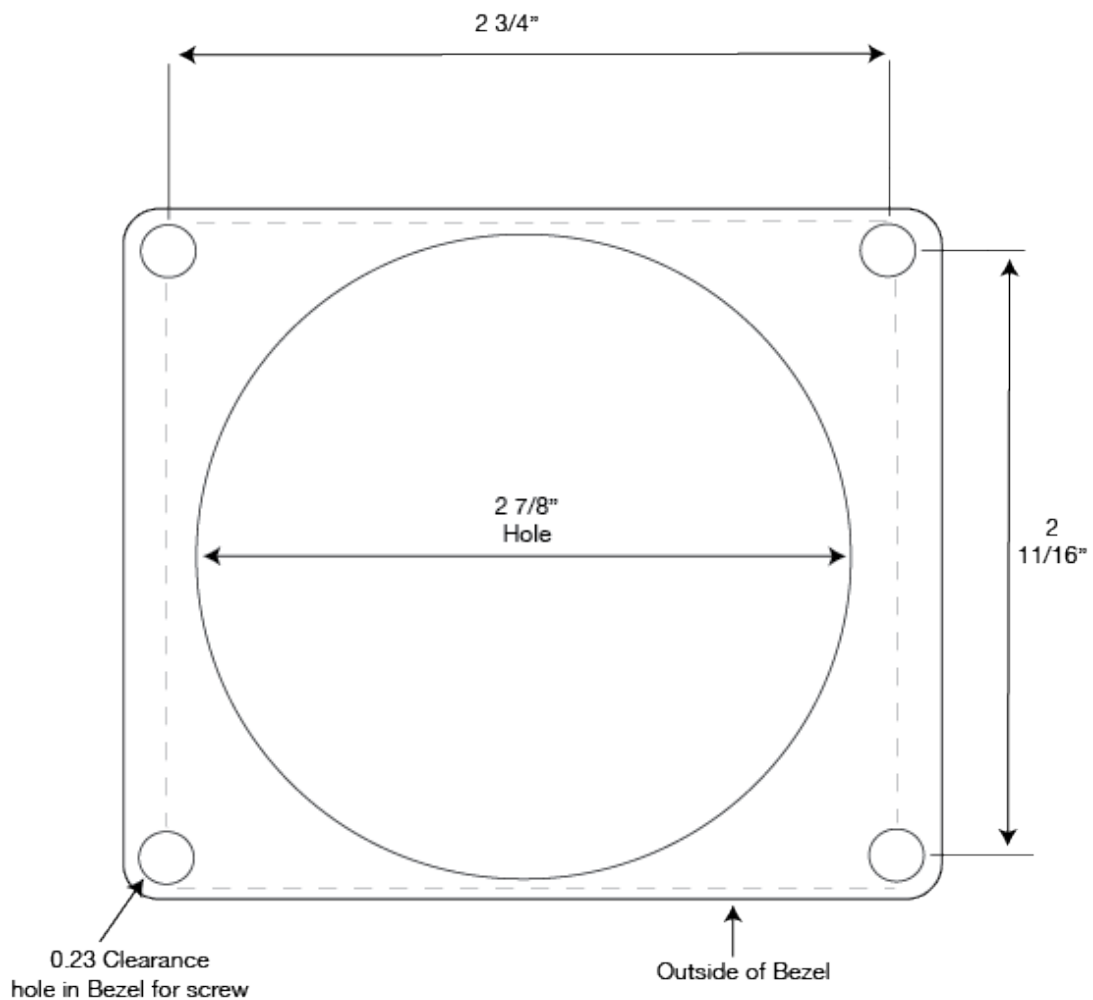

Figure 10. Panel Mounting Pattern

DC WIRING CONNECTIONS

Battery Cables

During high power operation, the battery cables to the inverter will see a very high current which will cause some voltage drop. This voltage drop represents power loss, and if it's too high it can affect the surge power capability of the inverter.

The best solution is to position the inverter close to the batteries (as previously stated, if lead-acid batteries are used, they need to be in a separate compartment). If they are within a few feet, then cables with suitable ampacity will work well, with low voltage drop (less than 2%). But if the inverter is more distant from the batteries, then a larger gauge wire may be needed to prevent excessive voltage drop. Use only high-quality copper wire.

The positive battery connection requires a fuse or circuit breaker that is within 18 inches of the battery or its cable entrance to the vehicle. The fuse rating should conform with safety standards and be determined according to the specified wire ampacity. Suggested wiring and protection for the WF-5318 and WF-5320 is shown in Figure 11.

ITEM	WF-5318	WF-5320
Rated Continuous Current	180	200
Minimum Safety Ground Wire Size	8 AWG	8 AWG
Minimum Dc Wire Size	2/0	2/0
	90 degrees C insulation	105 degrees C insulation
Maximum Dc Fuse Size	195 amps	225 amps

Figure 11. Dc wiring suggestion for WF-5318 and WF-5320.

The cables from the battery and fuse are connected to the positive and negative bolt terminals on the inverter. Be sure to observe correct polarity; the red terminal is positive (12 volts) and the black terminal is negative. The bolt terminals should be tightened to **6 ft-lbs or 8.1 Nm maximum torque.**

Rubber covers are provided for the terminations; slip these over the cable ends before attaching the cables, then after the connections are secured, the cover can be moved over the terminals for insulation and protection.

Notes:

- Make sure all the connections are tight. Loose connections can overheat and result in a potential hazard.
- The installation of a fuse must be on the positive cable. Failure to place a fuse on this cable running between the inverter and battery creates a safety hazard.
- Do not place anything between the battery cable lug and the terminal surface. If desired, a flat washer can be used on top of the terminal to protect it as the nut is tightened.
- During the first installation, a small spark is a normal phenomenon when the battery is connected because the internal capacitors will charge.

AC WIRING CONNECTIONS

CAUTION!

The electrical installation must conform to the local electrical codes and should be carried out by a certified technician.

To access the ac wiring compartment, loosen the two thumb screws as shown in Figure 12, tilt the cover, and pull it out with care.

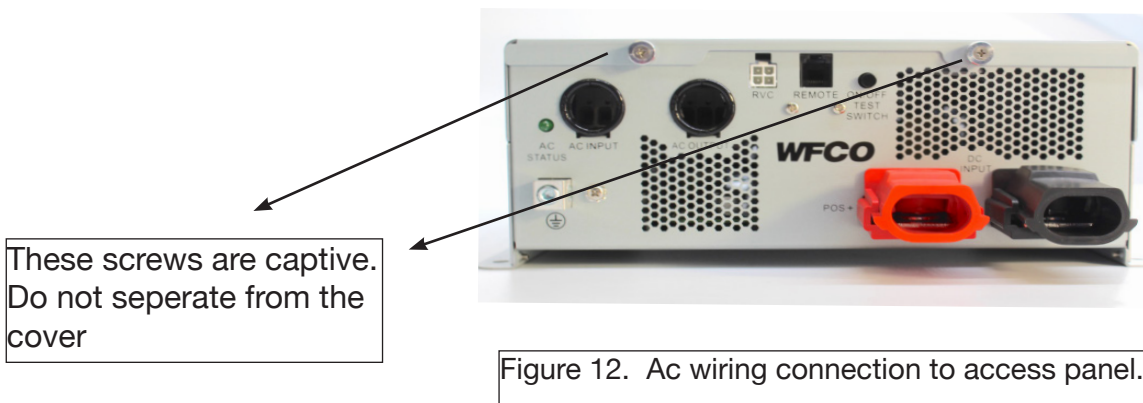

Figure 12. Ac wiring connection to access panel.

Connect ac output and ac input wiring to the correct terminals using the lever terminals. Each line, ground, and neutral wire must be correctly installed at the correct terminal. See Figure 13 for the wire colors, which must be followed for all of the ac wiring.

Conductor	Wire Color	For 15 Amp Inverter/Bypass Circuit	For 20 Amp Inverter/Bypass Circuit	For 25 Amp Inverter/Bypass Circuit
Line (L)	Black	Use 15 A Breaker & 14 AWG Wire	Use 20 A Breaker & 12 AWG Wire	Use 25 A Breaker & 10 AWG Wire
Neutral (N)	White	Use 15 A Breaker & 14 AWG Wire	Use 20 A Breaker & 12 AWG Wire	Use 25 A Breaker & 10 AWG Wire
Ground (G)	Bare copper, green, or green w/ yellow stripe	Use 15 A Breaker & 14 AWG Wire	Use 20 A Breaker & 12 AWG Wire	Use 25 A Breaker & 10 AWG Wire

Figure 13. Ac wire color, circuit breaker, and wire gauge

Be sure that the input and output wiring is correct; it's a good idea to label the wires. To attach the wires, lift the connector levers up, place the wires in the holes, then snap the levers down. See Figure 14.

Figure 14. Ac wiring at inverter for 120-volt input and output circuits.

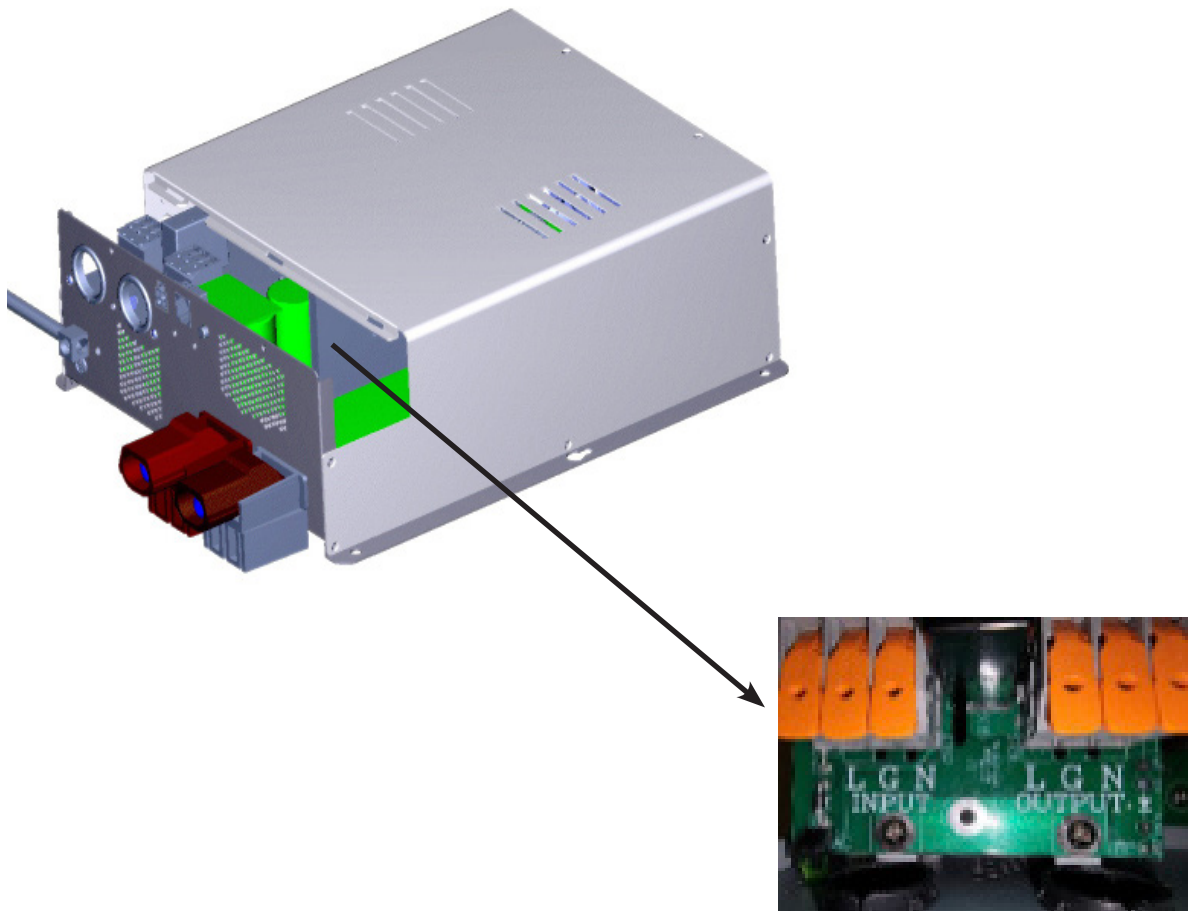

Cover removed to show where the terminals are

INVERTER GROUND CONNECTION

Pass-through Ac Ground Bonding

For a safe installation, both the input and output ac grounds must be properly connected to the inverter along with the line and neutral. When the inverter is bypassed (not inverting), this ground wire connection is passed through to the output circuit and the load either directly or via the distribution panel.

This preserves the single neutral-ground bond at the service panel, as the NEC requires. These ground wires are usually sheathed with the line and neutral. This ground is critical – it allows the circuit breaker to prevent grounded metal items from being energized in case of a short circuit.

Inverter Safety Ground

When inverting, as the NEC also requires, the pass-through ground connection is opened, and the inverter output neutral is connected to the local safety ground instead. This happens automatically in the inverter, as long as the local ground connection is correctly wired.

A separate terminal is provided on the inverter for this safety ground. The code for RV applications requires 8 AWG or larger wire to be used for this ground connection. This connects the inverter ground terminal to the vehicle or trailer chassis. Be sure to remove any paint or corrosion from the chassis to ensure a positive connection to the metal with a tooth washer, a ring lug, and a bolt. See Figure 15.

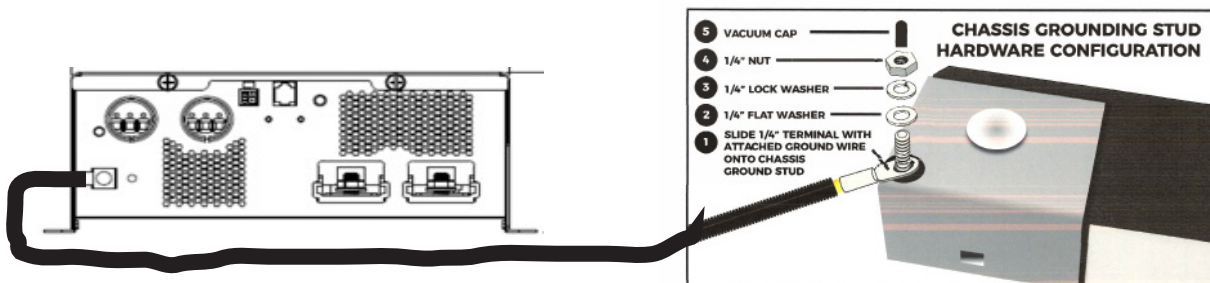

Figure 15. Inverter ground is connected to chassis with 8 AWG wire.

Neutral Grounding Connection Setting

A ground screw on the side of the unit allows, for some special non-RV applications, disconnecting the neutral-ground connection while inverting. See Figure 18.

The default setting is option A: YES - CONNECTION BETWEEN NEUTRAL CONDUCTOR OF THE AC OUTPUT AND SAFETY GROUND. For RV applications, be sure this screw is tightly secured in the correct position.

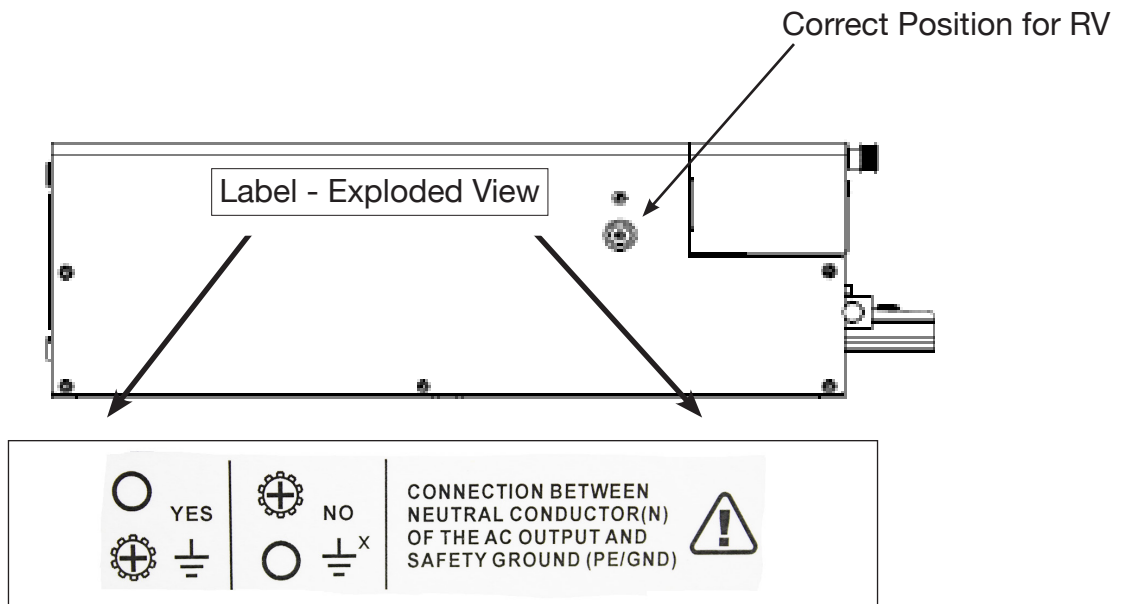

Figure 16. Inverter neutral-ground connection.

GFCI CONNECTOR

If the converter output is connected to a receptacle outlet, and the receptacle is near a water tap, a wet location, or outdoors, it will need a GFCI receptacle. See the System Design section on page 17 for a list of approved GFCI receptacles.

CONTROL PANEL CONNECTION

The control panel is connected with the supplied RJ-25 cable. One end connects to the back of the panel and the other end connects to the inverter at the “Remote” connector. For control panel operation, be sure the “TEST” switch is not pressed in (use the out position).

TESTING THE INVERTER

After the inverter is installed and wired, inspect all connections, verify all wire routing, and make sure the connections are tight and properly made. Check that the relevant circuit breakers are turned on. Then the system should be ready to be tested as follows:

TESTING THE INVERTER

After the inverter is installed and wired, inspect all connections, verify all wire routing, and make sure the connections are tight and properly made. Check that the relevant circuit breakers are turned on. Then the system should be ready to be tested as follows:

1. Test the ac wiring with bypass by leaving the inverter off. Connect the shore power or external power source. At this point the inverter-powered circuit should be energized.
2. Measure the voltage at an outlet to verify the correct voltage and connector wiring. The voltage should be the same as the external source voltage. Also check the voltage between the neutral terminal and the chassis of the vehicle or trailer. This voltage should be zero or very low, less than a few volts.
3. Next, turn off or disconnect the external ac source. Then turn on the inverter. To do this, press the power button on the control panel and hold it for two seconds.

If the remote panel is not connected, the inverter can be turned on by using the convenient “ON/OFF TEST SWITCH” pushbutton on the inverter. When it is pressed, the inverter will start regardless of the control panel or whether it is connected. ***Be sure to leave the switch out when done testing, otherwise the control panel will not function.***

4. With the inverter operating, check the output voltage at an inverter outlet or receptacle. The voltage should be about 115 volts ac from line to neutral or line to ground. The control panel will read that out also. Check the voltage between the neutral terminal and the chassis of the vehicle or trailer. This voltage should be zero or very low, less than a few volts.
5. Now reconnect the external ac voltage source. The inverter should go into bypass. Then measure the inverter outlet circuit voltage. This should match the external ac voltage again, while the inverter is in standby.

Troubleshooting Guide

Problem	Possible Cause	Solution
Inverter does not provide 115 V ac at output when plugged into shore power.	Shore power is not connected.	Plug shore power cord into power source.
	Shore power breaker is tripped.	Reset shore power breaker; verify correct voltage at pedestal.
	Shore power voltage is out of range.	Check shore power voltage; it should be between 90 volts and 130 volts.
	Inverter output circuit breaker has tripped.	Internal breaker will automatically reset within one minute. If it trips again, reduce the load current.
	Branch circuit breaker that supplies the inverter has tripped.	Reset the breaker. If it trips again, reduce the load current.
Inverter does not provide 115 V ac at output when operating on battery only.	Inverter is not turned on.	Hold power button for three seconds to turn on inverter.
	Battery polarity reversed.	Check and correct the battery wiring.
	Battery fuse or breaker has opened.	Replace fuse or reset breaker.
	Battery voltage is low.	Recharge battery. Inverter operates from 10 to 16 volts dc.
	Inverter has been overloaded.	Reduce load; turn off inverter then turn on again.
	Inverter branch circuit breaker or GFCI has tripped.	Reset breaker or GFCI.
Remote control panel is dark and will not turn on.	No dc power to inverter.	Connect a charged battery to the inverter.
	Test button on the inverter has been left on (pressed in).	Set the test button so that it is off (press it to the out position).
	Remote control panel cable has been damaged or disconnected.	Reconnect or repair/replace the cable.
Remote control panel shows a flashing, dark, or incomplete display.	Panel has been connected or disconnected while operating; communication lost.	Reboot panel: disconnect cable, reconnect cable, then turn inverter off/on again.

WARRANTY INFORMATION

ARTERRA DISTRIBUTION WARRANTY

We guarantee this product against defects in materials and workmanship for a period of 24 months from the date of purchase. Please contact WFCO or your local WFCO authorized distributor for RMA (Return Material Authorization) service. Please note that WFCO will ensure our products are operational before delivery and the warranty service is offered to the unit which has defect caused under normal use, in the judgment of WFCO's technician. The warranty is null and void under the following circumstances:

- * If the unit has been damaged through abuse, misuse, negligence (such as bumping, wetting), incorrect voltage supply, air or water pollution accidents and natural calamities.
- * If the serial number has been altered, effaced, or removed.

WFCO Address:
2021 Aeroplex Drive, North
Elkhart, IN 46514
574-294-8997
www.wfcotech.com

WFCO Power Pro Tech Support:
support@wfcoelectronics.com
574-294-8997
www.wfcotech.com

LEGAL PROVISIONS

Copyrights 2023 WFCO Electronic IND. CO. All Rights Reserved.

No part of this document may be reproduced in any form for any purpose without the prior written permission of WFCO Electronic IND. CO. For the conditions of the permission to use this manual for publication, contact WFCO Electronic IND. CO., LTD. In all related WFCO product activities, Neither WFCO Electronic IND. CO., LTD. nor its distributors or dealers be liable to anyone for indirect, incidental, or consequential damages under any circumstances. Specifications are subject to change without notice. Every attempt has been made to make this document complete, accurate, and up to date. WFCO Electronic IND. CO., LTD reserves the right to make changes without notice and shall not be responsible for any damages, including indirect, incidental, or consequential damages, caused by reliance on the material presented, including, but not limited to, omissions, typographical errors, arithmetical errors, or listing errors in the content material. All trademarks are recognized even if these are not marked separately. Missing designations do not mean that a product or brand is not a registered trademark.

WFCO



TECHNOLOGIES

*Innovating the future of **RV POWER.***

**WFCO Address:
2021 Aeroplex Drive, North
Elkhart, IN 46514
574-294-8997
www.wfcotech.com**



EXPERT PRODUCT SUPPORT

**Power Pros Technical Support
(574) 294-8997**