

Product Manual



WF-8900-AD SERIES POWER CENTER

- WF-8935-AD • WF-8545-AD • WF-8955-AD • WF8975-AD
(The Power Center model number is located on the front panel label next to the breakers)



• 2021 Aeroplex Drive, NorthElkhart, IN 46514 • (574)-294-8997 • www.wfcotech.com

TABLE OF CONTENTS

<u>SAFETY INFORMATION</u>	1
<u>GENERAL INFORMATION</u>	
Reverse Battery Protection.....	1
Blown Fuse Indicators	2
Automatic Cooling Fan	2
AC Voltage Indicators	2
Over-Temperature Protection	2
Electronic Current Limiting	2
Short Circuit Protection	2
<u>CIRCUIT PROTECTION</u>	
DC Fuses	3
AC Circuit Breaker	3
UL-Listed Main Circuit Breaker List.....	4
UL-Listed Branch Circuit Breaker List.....	4
<u>OPERATIONAL FEATURES</u>	
Auto Detect	5
Three-Stage Smart Charging.....	5
Two-Stage Smart Charging	6
<u>TROUBLESHOOTING INSTRUCTIONS</u>	
Converter Output Voltage.....	7
Reverse Polarity Fuses	8
Troubleshooting Flow Chart.....	8
<u>GENERAL COMPLIANCE INFORMATION</u>	
Agency Listings.....	9
<u>INSTALLATION INSTRUCTIONS</u>	
Mounting the Enclosure.....	10
Wiring the AC Breakers.....	10
Wiring the DC Fuse Board	11-12
<u>SPECIFICATIONS</u>	13
<u>WARRANTY INFORMATION</u>	14-15

 **WARNING**

RISK OF ELECTRICAL SHOCK

Disconnect and isolate all power supplies before making electrical connections. More than one disconnection or isolation may be required to completely de-energize equipment. Contact with components carrying hazardous voltage can cause electric shock and may result in severe personal injury or death.

 **NOTICE**

All wiring must conform to local, national and regional codes and regulations. Use copper conductors ONLY for all wire connections. Do not exceed the electrical ratings for the WF-8900-AD Series Power center or the equipment connected to it. Failure to follow these precautions may cause permanent failure and/or electrical shock which could result in severe personal injury or death.

 **CAUTION**

EQUIPMENT SERVICING

This product should be installed by an experienced and certified technician. CAUTION and care must be taken when servicing this equipment. To prevent severe shock or electrocution, consult your servicing dealer.

 **WARNING**

SPARK HAZARD

This unit employs components that can produce arcs or sparks. To prevent fire or explosion, do not install in compartments containing batteries or flammable materials (i.e. gas). This product is NOT ignition protected.

 **CAUTION**

DO NOT OBSTRUCT VENTILATION

To prevent fire, do not cover or obstruct front cover ventilation openings as overheating may result. This series is a zero-clearance design, and as such, the only means of ventilation is through the front cover openings.

 **WARNING**

BATTERY SYSTEM

Use converter only on appropriate battery systems. Other usage may cause personal injury and damage. Consult all battery manufacturer's recommendations for additional safety information before use.

GENERAL INFORMATION

WF-8900-AD Series Power Center Safety Features

REVERSE BATTERY PROTECTION

The WF-8900-AD Series Power Centers will charge the 12-volt House battery if installed. A battery DOES NOT have to be installed for WF-8900-AD Series Power Center converter operation. When a battery is installed, two reverse polarity fuses protect the converter circuitry. The fuses are located along the left-center edge of the DC fuse board below the VCC+ lug. Refer to Figure 1 on page 3. This feature prevents permanent damage to the converter from a battery connected into the circuit backwards. In addition to protecting the converter section, the reverse polarity fuses are the main connection between the converter and the DC fuse board.

The fuse values and quantity vary depending on which WF-8900-AD Series Power Center you have. Refer to the table and drawing below.

- WF-8935-AD – 40A (1) *NOTE: Only one of the two Reverse Polarity terminals is used.
- WF-8945-AD – 30A (2)
- WF-8955-AD – 40A (2)
- WF-8965-AD – 20A (4)
- WF-8975-AD – 20A (4)

BLOWN FUSE INDICATORS ON DC FUSE BOARD

The DC Fuse Board has individual blown fuse indicators as standard equipment. Each of the 11 DC fuse circuits contain a Red LED to indicate a blown fuse. If one of the circuits draws more current than the rating of the fuse, the fuse will blow. When this occurs, the Red LED for that circuit will illuminate. **NOTE:** The fuse board employs surface mount LEDs which are barely visible to the naked eye. Replace the blown fuse with a known good fuse of the same rating. **NOTE:** If the replacement fuse blows again, check that circuit for a short or overload condition.

AUTOMATIC COOLING FAN

The cooling fan in the WF-8900-AD Series Power Center is incremental and is controlled by the current drawn out of the converter to the applied load. The on-board microprocessor increases fan speed as the total load increases and decreases fan speed as the load decreases. Unlike traditional temperature-controlled fans, the load-controlled fan provides better component cooling by avoiding temperature spikes which can lead to premature component failure.

OVER-TEMPERATURE PROTECTION

If the internal temperature of the converter exceeds a critical point, it will shut down. This protects the unit from excessive heat that may damage sensitive components. The unit will restart once the temperature inside has dropped.

ELECTRONIC CURRENT LIMITING

If the output current exceeds the maximum rating for the WF-8900-AD Series Power Center converter, the output current will remain constant, but the output voltage will begin to drop. If this occurs, the unit will recover once loads are reduced.

SHORT-CIRCUIT PROTECTION

Should a short circuit occur in the RV, the WF-8900-AD Series Power Center converter will drop the voltage output to zero volts. If the short-circuit condition is removed and no other fault conditions are detected, the converter will resume normal operation. However, short-circuit conditions are **dangerous**, and an RV will require inspection by a qualified service technician.

CIRCUIT PROTECTION

WF-8900-AD Series Power Center Fuses and Breakers

DC FUSES (12 VOLTS)

The DC fuse board has spaces for eleven DC circuits. This includes two 30 Amp circuits (positions F10 and F11) to be used for slide-outs or other higher current loads. These circuits have a maximum rating of 30 Amps. The remaining nine circuits have a maximum 20 Amp rating. The circuit fuses and the Reverse Battery Protection fuses should be replaced with ATC or ATO automotive type fuses such as:

- Littelfuse type 257
- Bussmann type ATC

AC CIRCUIT BREAKERS (120/240 VOLTS)

The AC Breaker side of the WF-8900-AD Series Power Center is located on upper the left side. The WF-8900-AD Series Power Center accepts standard residential breakers. A total of ten breakers can be installed: one 30 Amp Main breaker and up to a maximum of nine AC Branch circuits when using duplex breakers. A list of factories tested and approved breakers follows.

The breakers may be purchased at most big-box department stores and home centers.

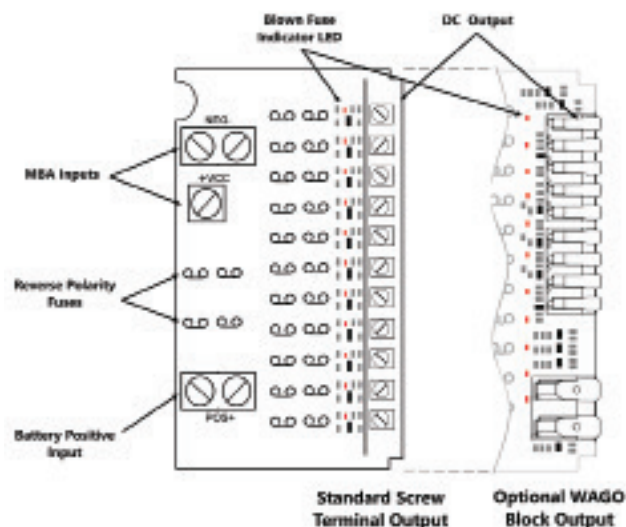

Figure 1

UL-LISTED MAIN CIRCUIT BREAKERS, RATED FOR 120V, MAXIMUM 30A

The following breakers have been factory tested and approved for use as 30 Amp Main breakers in the WF-8900-AD Series Power Center:

Manufacturer	Model/Cat. No./Type
Cutler Hammer	Type BR and C
Thomas Betts	Type TB or TBBD
ITE/Siemens	Type QP or QT
Square D	Type HOM or HOMT
Murray	Type MP-T or MH-T
General Electric	Type THQL or THQP

UL-LISTED BRANCH CIRCUIT BREAKERS, RATED FOR 120V, MAXIMUM 20A

The following breakers have been factory tested and approved for use as Branch breakers in the WF-8900-AD Series Power Center:

Manufacturer	Model/Cat. No./Type
Cutler Hammer	Type BR and C, Type BRD, BD and A
Thomas Betts	Type TB or TBBD
ITE/Siemens	Type QP or QT
Square D	Type HOM or HOMT
Murray	Type MP-T or MH-T
General Electric	Type THQL or THQP

When replacing any of the installed circuit breakers, the replacement should be of the same manufacturer, type designation, and equal interrupting rating, not to exceed 30 A. The “Short-Circuit-Current” rating for the breaker should be 10,000 Amps. Breaker Filler Plates:

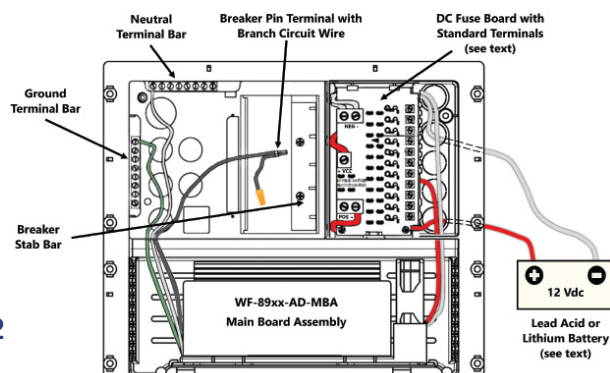

Figure 2

OPERATIONAL FEATURES



AUTO DETECT

This product includes the exclusive “Auto-detect” feature for the charging of batteries. With this new technology, the power converter will evaluate the charging cycle of a battery, determine the type of battery being used, and then choose the appropriate charging program (profile) to provide for the best performance and maintenance of that battery.

Because of the differences of Lead Acid, AGM and Lithium type batteries, a system that provides a charge to the battery or batteries must be able to accommodate the different charging requirements. With the use of the “Auto-detect” product, the charging requirement is able to be “detected” and is then automatically set for the type of battery being used. For standard Lead Acid and AGM batteries, WFCO power converters still use the Three-Stage Smart Charging to effectively maximize battery life by monitoring through the different phases of the charge cycle. On the other hand, Lithium batteries will prefer the use of only two stages when charging, and therefore the power converter will charge using the WFCO Two-Stage Smart Charging system.

LEAD ACID & AGM THREE-STAGE SMART CHARGING

In order to maximize battery life for lead acid and AGM batteries, it is best to charge batteries slowly, keep them topped off with a trickle-charge when the RV is not being used. The 3-Stage “smart” charger continuously measures the battery voltage output and regulates the amount of charge using three modes of operation: Absorption, Bulk and Float modes.

All WFCO power converters have automatic three-stage switching power supplies. The converter senses which mode it needs to be in by checking the RV system voltage.

ABSORPTION MODE

The converter normally provides a constant target output voltage of 13.6 VDC (nominal) to power all the branch circuits. However, it is current limited, and if the output (load) current reaches its maximum, the output voltage will drop as necessary to hold the converter’s maximum output current level (the Amperage rating) without exceeding it.

BULK MODE

If the output current reaches its maximum (normally caused by a discharged battery), this will cause the converter to go into Bulk Mode, which means the target output voltage will change to 14.4 VDC and a timer will start. Although the converter is outputting 14.4 VDC, you will not be able to read that on a voltmeter due to the voltage-current relationship. From the paragraph above, as load current increases, output voltage decreases. The actual output voltage will not rise until the load current is reduced, which happens naturally as the battery charges or if 12 VDC appliances are turned off.

Bulk Mode will be maintained until the current draw drops to approximately five Amps, or until the timer reaches four hours (whichever happens first). Then the target output voltage is changed back to 13.6 VDC for Absorption Mode. Lights that are powered from the output may change brightness slightly at that time.

Note: For a detailed explanation of the charging modes, please refer to our publication “Theory of Operation”, document #AD-TD-0001-0.

FLOAT MODE

The third mode of charging is what is called the “float” charge. This mode is designed to provide a “trickle charge” to the battery after the system observes no significant variations in current draw over a long period of time. When in “float” mode, the voltage will reduce from 13.6V to 13.2V and supply the “trickle charge” which helps to preserve the life of the battery while keeping it charged and ready for use. A change in DC current will cause the converter to exit the mode and return to the Absorption mode and then to Bulk mode if required.

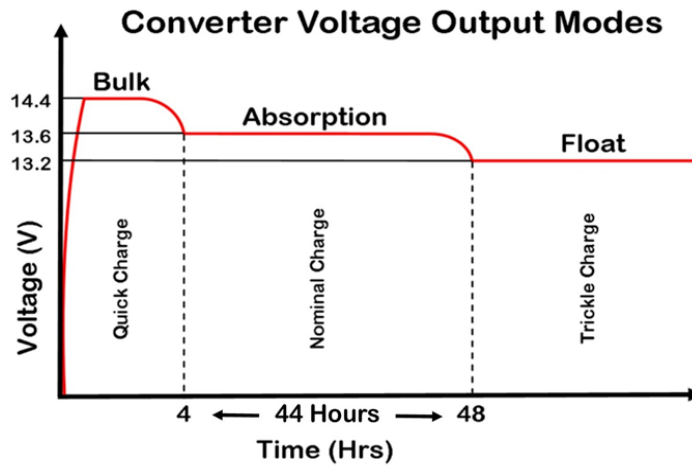

Figure 3

LITHIUM TWO-STAGE SMART CHARGING

The two-stage “smart” charger continuously measures the battery voltage output and regulates the amount of charge using two modes of operation: Bulk and Absorption mode.

TWO-STAGE CONVERTER VOLTAGE OUTPUT MODES

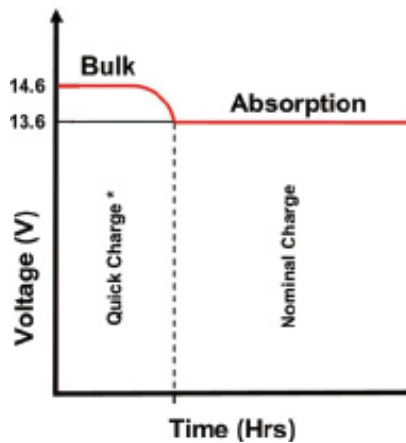

Figure 4

BULK MODE

This mode is designed with two purposes in mind. First, to quickly restore the energy back into the battery. Second, to ensure the lithium cells inside the battery remain balanced. This is accomplished by boosting the output voltage to 14.6 VDC and allowing the maximum current to flow as required by the loads.

The bulk mode stage could last anywhere from one to four hours based on the battery and load current which is being used. For a full battery, the bulk stage has a minimum time requirement of one hour, which allows the lithium cells inside the battery the time required to “balance”.

For an empty battery, the bulk stage has a maximum time requirement of four hours. If your application requires longer than four hours (such as a larger battery bank > 200 Ahr), a simple cycling of power will reset the timers.

As the energy is restored into the battery, the DC system voltage will climb and the current from the converter will decrease. If the total amperage draw from the converter reaches a preset point (within the one-to-four-hour timer), the converter is designed to drop out of bulk mode.

ABSORPTION MODE

This mode is designed with 1 purpose in mind. This purpose is to provide a safe operating voltage for all loads in the RV. This is accomplished by reducing (from bulk mode) the output voltage to 13.6 VDC and remaining at this voltage until the power is cycled to the converter.

The absorption mode stage is the default or normal mode of operation, which has no timer associated with it. In this mode an output of 13.6 VDC is provided to the DC circuits in the RV. This voltage has a long-term history as the acceptable voltage for all loads in the RV, and should not place undue stress (nor reduce the longevity) of the lights and appliances in the RV. This is not to say that all loads will have an issue with a constant higher voltage; however, some loads may have an issue. Please refer to the individual manufacturer’s specifications for acceptable operating voltage range of the connected load.

TROUBLE SHOOTING INSTRUCTIONS

Troubleshooting the WF-8900-AD Series Power Center

Refer to the Troubleshooting Guide for the WF-8900-AD Series Power Center (Figure 5) on page 8.

CHECKING CONVERTER OUTPUT VOLTAGE

Before checking the WF-8900-AD Series Power Center output voltage, disconnect the battery cables at the battery. Make sure the converter is plugged into an AC source (105-130 VAC).

Check the converter output voltage at the battery with a voltmeter. Place the meter probes on the disconnected battery cables; place the Positive (red) meter probe on the + Positive battery wire and place the Negative (black) meter probe on the - Negative wire on the battery cable.

Be sure you have good connections at the cables. If the voltage reads 13.6-14.6V, the converter is functioning properly.

If the converter output voltage at the battery reads 0.0 VDC, or if the battery is not charging, check for an open inline fuse in the battery wire circuit. One may have been installed by the RV manufacturer. Also check for loose wiring connections.

CHECKING FOR REVERSE BATTERY HOOKUP (REVERSE POLARITY FUSES)

If there is no DC output coming from the WF-8900-AD Series Power Center converter section, first check the reverse polarity fuses on the fuse board. Then, visually inspect the fuses for any breaks in the fuse element. If no breaks are found, use a continuity tester to check for continuity. If the reverse polarity fuses are blown, it means the RV battery was accidentally connected in reverse, either at the battery or at the converter. Investigate the connections and reconnect the cables properly. Replace the fuse with the same type and amperage rating as the original.

IMPORTANT: These fuses protect the converter from damage if the RV battery is accidentally connected in reverse. A reversed battery connection, even if for only a second, will cause these fuses to blow.

If the above checks have been made but the converter output still reads 0.0 VDC, the converter is not functioning properly. Contact the Arterra Distribution Power PROs at (877) 294-8997. Before placing the call, please have available the WF-8900-AD Series Power Center model number from the front panel label and the 14-digit serial number from the bar code tag located on the MBA mounting plate.

AC REVERSE POLARITY (AUDIBLE ALARM)

This power center is equipped with an AC REVERSE POLARITY PROTECTION feature. Should the incoming AC neutral wire and lead wire be connected backwards at the power center, an alarm located in the power center enclosure will sound. This alarm will continue to sound until the AC wires are connected correctly.

Troubleshooting Guide for WF- 9800 Series Deck Mount Converters

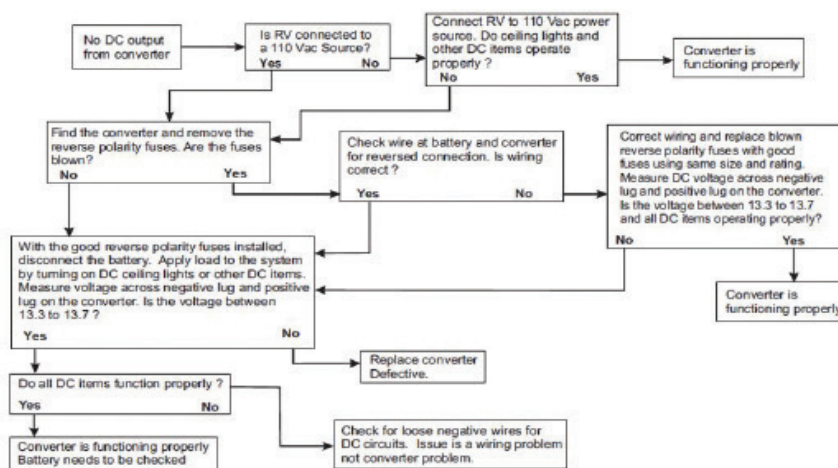

Figure 5

Should it be determined that the converter section of the WF-8900-AD Series Power Center needs to be replaced, removal of the Main Board Assembly is a simple process.

REPLACING THE CONVERTER SECTION (MBA)

Make sure no AC power is coming into the RV from either the Shore Power cord or an on-board generator. Remove and set aside the Reverse Polarity Fuses to disconnect the converter section from the rest of the RV DC power.

Perform the following steps:

1. Remove the door assembly by loosening the two screws located in the upper left and right corners. The screws are captive and will not fall out. Pull forward and outward on the door assembly to clear the case.
2. In the upper left portion of the fuse board, loosen the NEG- lug (White wire) and the VCC+ lug (Red wire). Do not back the lug screws all the way out.
3. Locate the tab at the bottom of the fuse board holding the board in place. Gently depress the tab allowing the fuse board to be pulled forward.
4. With the fuse board pulled slightly away from its mounting, pull the Red and White wires out of the lugs.
5. In the AC section of the enclosure, locate the Black wire coming up from the converter in the lower section. As an extra precaution, **MAKE SURE THE CONVERTER BREAKER IS IN THE OFF POSITION**. Remove the wire from the breaker. **NOTE:** this wire has a metal pin terminal on the end inserted into the breaker. Remove and position out of the way any wire connected to the pigtail.
6. Locate and remove the converter's Green Ground wire attached to the AC Ground bar on the left side of the compartment. In a similar fashion, locate and remove the converter's White Neutral wire attached to the AC Neutral bar at the top of the compartment.
7. In the converter compartment, remove the two screws at the front of the MBA holding it in place. Slide the MBA forward routing the wires through the slots in the case until the MBA clears the enclosure.

If the MBA is being returned under a warranty claim, follow the packaging instructions in your warranty claim packet.

When installing a replacement MBA, reverse the order of steps 1-7. Make sure all wiring connections are torqued to the proper values found in the torque chart located on the back of the door assembly.

GENERAL COMPLIANCE INFORMATION

Agency Listings

UL

The WF-8900-AD Series Power Centers are UL-Listed, and cUL-Listed (Canadian).

FCC COMPLIANCE CLASS B

NOTE: This equipment has been tested and found to comply with the limits for a Class B digital device, pursuant to Part 15 of the FCC Rules. These limits are designed to provide reasonable protection against harmful interference when the equipment is operated in a commercial environment. This equipment generates, uses, and can radiate radio frequency energy, and if not installed and used in accordance with the instruction manual, may cause harmful interference to radio communications. Operation of this equipment in a residential area is likely to cause harmful interference in which case the user will be required to correct the interference at his own expense.

INSTALLATION INSTRUCTIONS

Installing the WF-8900-AD Series Power Center

MOUNTING THE ENCLOSURE

The WF-8900-AD Series enclosure should be mounted in an accessible area such as a wall or in the side of a cabinet. The front of the enclosure should not be obstructed to allow free air flow for the cooling fan. The enclosure will slide into a rough opening of 12 3/16" W x 10 7/8" H. The enclosure depth is 7 1/4". After wiring is completed, the enclosure fastens to the wall or cabinet using 8 wood screws (not supplied).

NOTICE

RISK OF ELECTRICAL SHOCK

Disconnect or isolate all power supplies before making electrical connections. More than one disconnection or isolation may be required to completely de-energize equipment. Contact with components carrying hazardous voltage can cause electric shock and may result in severe personal injury or death.

WIRING THE AC BREAKERS

Make sure no AC power is coming into the RV from either the Shore Power cord or an on-board generator. Determine the proper size breakers for the loads the WF-8900-AD Series Power Center will be powering. You can use either single or duplex breakers, or a combination of both. We recommend that all the breakers used be of the same brand. When using duplex style circuit breakers, a total of 10 breakers can be mounted in the WF-8900-AD Series Power Center: 1 Main breaker and 9 Branch breakers. Refer to the tables on page 6 for a selection of approved breakers. The Main breaker should be 30 Amp and is to be installed in the top-most position. See the wiring diagram below. A hold down clip is provided to keep the breaker securely in place.

The 30 Amp power cord is routed through the large knockout in the wiring compartment and secured with a Romex clamp. The Black (Hot) wire is connected to the 30 Amp Main breaker as shown. The White (Neutral) wire is connected to the Neutral Terminal bar at the bottom of the wiring compartment. The Green (Ground) wire is connected to the Ground Terminal bar also located at the bottom of the compartment. Route the Romex leads for the Branch circuits through the Strain Reliefs in the back of the wiring compartment. In a similar fashion, connect the Black wire to the Branch breaker and the White and Green wires to the appropriate Terminal bar. Also, route an 8 AWG Green or bare Ground wire through the small diameter hole located next to the Ground bar to the vehicle chassis.

The Black power wire for the converter has a pigtail connection. The metal pin is inserted in the Branch breaker designated for converter power. The end with the wire nut can be used to power another circuit if necessary. If not used, leave the wire nut installed and push the wire to the side.

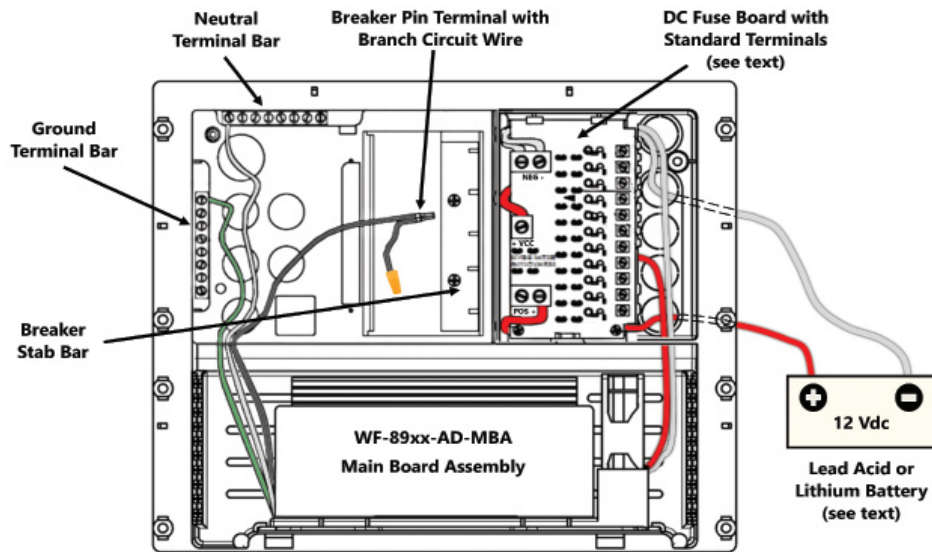

Figure 6

WIRING THE DC FUSE BOARD

Make sure the house battery is disconnected before beginning the DC wiring. Determine what DC loads are to be connected to the fuse board and what position they will occupy. Circuits F10 and F11 can be used for slide-outs or other higher current loads and can have a maximum 30 Amp ATO or ATC fuse installed. The remaining circuits are general purpose and can have up to 20 Amp ATO or ATC fuses installed. Make sure the fuses are seated properly.

All models have output screw terminal connections. Strip approximately 1/4" of insulation from the load's wire and insert into the screw terminal. Tighten the terminal to the torque specified on the back of the enclosure.

Connect the heavy wire (Red) coming from the battery to the POS+ lug located directly below the Reverse Polarity fuses. Make sure this lug is torqued properly.

As a last step, install a separate bus bar in a location behind the converter. This bus bar can be purchased from a local home center or hardware store. For the WF-8935-AD/8945-AD/8955-AD, run an 8 AWG wire from the NEG-lug on the top left of the DC fuse board to this bus bar. For the WF-8965-AD/8975-AD, run a 6 AWG wire. Connect the battery negative wire to this bus bar along with all the negative DC load wires. Also, run a wire from the bus bar to chassis ground.

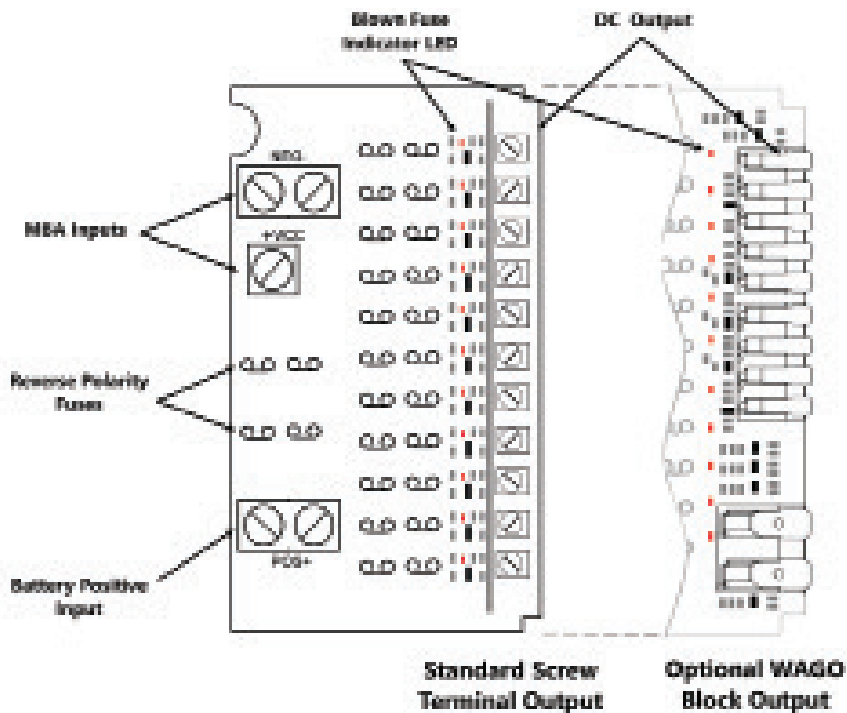

Figure 7

WF-9800 Converter Specification			
Model No.	WF-9835	WF-9845	WF-9855
Converter Input Power:			
Voltage	105-130VAC		
Frequency	60Hz		
Max.Input Current @105VAC	7A	9A	11A
Max Power	600 watt	770 watt	940 watt
Converter Output Power:			
Continuous Power:	475 watt	610 watt	750 watt
Rated DC Output Voltage	13.6V		
Rated DC Current	35A	45A	55A
Charging Control	Automatically controlled by microprocessor		
Charging Modes	3-stage Intelligent charge		
Intelligent Charge Modes	Absorption, Bulk and Storage		
Battery Adaptability	LA/AGM		
Absorption Charge Voltage	13.6V		
Bulk Charge Voltage: (4 Hrs)	14.4V		
Storage Charge Voltage	13.2V		
Regulation	± 1% accuracy against input or load changes		
Cooling Fan	Two speed according to the DC load Amperage		
VA Efficiency	> 80% (under 70% of load condition)		
Protection:			
Overload	Current-limiting & shut down; auto recovery upon return to normal load		
Short-Circuit	Shut down & auto recovery upon return to normal		
Over-Temperature	Shut down & auto recovery upon return to normal		
Battery Reverse Polarity	Protected by Fuse; same rated fuse replacement required		
DC Distribution Board:			
DC Battery Lugs: NEG-,POS+	Lugs accept 2 to 14 AWG wire; Lug screws are 5/16" Allen Head		
Mechanical:			
Dimensions	4 5/8"W x 4"H x 7 1/2"D 117.5 mm W x 101.6 mm H x 190.5 mm D	4 3/4"W x 4"H x 8 3/4"D 120.7 mm W x 101.6 mm H x 222.3 mm D	
Weight	4 lbs. / 1.8 kg	5.25 lbs. / 2.4 kg	5.5 lbs. / 2.5 kg
Environmental Condition:	20 ~ 90% Non-condensing		
Agency:	UL458 certified; FCC Class B compliant		

Figure 8

CONSUMER LIMITED WARRANTY for WFCO Technologies Products

WFCO extends, to the original owner, a Two-Year Limited Product Warranty. This warranty is in effect from the date of original purchase for a period of two years. This limited warranty is extended specifically for and is limited to Recreational Vehicle application and is only valid within the continental United States, Alaska, Hawaii and the Provinces of Canada. WFCO warrants, to the owner, that its products are free from defects in material and workmanship under normal use and service based on its intended use and function. This warranty is limited to the repair or replacement, at WFCO's discretion, of any defective parts or defective assembly. Any implied warranties of merchantability or fitness for intended use are limited in duration unless applicable State Law provides otherwise. You may have other rights as specified by each individual state.

EXCLUSIONS AND LIMITATIONS

The OEM warranty specifically does not apply to the following:

- Any WFCO product that has been repaired or altered by an unauthorized person.
- Any damage caused by misuse, faulty installation, testing, negligence, accident or any WFCO product installed in a commercial vehicle.
- Any WFCO product, whose serial number has been defaced, altered or removed.
- Any WFCO product, whose installation has not been in accordance with the WFCO written instructions.
- Any consequential damages arising from the loss of use of the product including but not limited to inconvenience, loss of service, loss of revenue, loss or damage to personal property, cost of all services performed in removing or replacing the WFCO product. Specifications are subject to change without notice or obligation.
- Any WFCO Technologies products sold through unauthorized Internet sources (Example: eBay) will be excluded from all warranty coverage offered by WFCO Technologies.

CONSUMER WARRANTY CLAIM PROCEDURE

Upon determination and validation by an authorized OEM dealer that a WFCO product has a defect, a Return Goods Authorization (RGA) number will be required before the product can be returned. The RGA number can be requested by completing the Warranty Information Fax Sheet and appropriate Troubleshooting Form found at wfcoelectronics.com. Once these forms have been completed, email the forms along with Proof of Purchase to:

warranty@wfcoelectronics.com or fax the three documents to the Warranty Department at **(574) 294-8698**.

After receipt of the forms, an RGA number will be issued. This number shall appear on all correspondence with warranty service.

Upon validation of the warranty, WFCO shall replace the product with a like product. The RGA number shall be placed on the outside of the carton used to return the product for ease of identification. Do not mark directly on the product. The product must be packaged properly to avoid further product damage which could cause a non-warrantable condition.

WARRANTY ASSISTANCE

The consumer may contact the selling Dealer or OEM for warranty assistance.

The consumer may also contact WFCO Technologies, exclusive distributor of WFCO Products at: **(574) 294-8997** or Fax **(574) 294-8698**.

BACK SIDE OF THE WF-8900-AD SERIES POWER CENTER

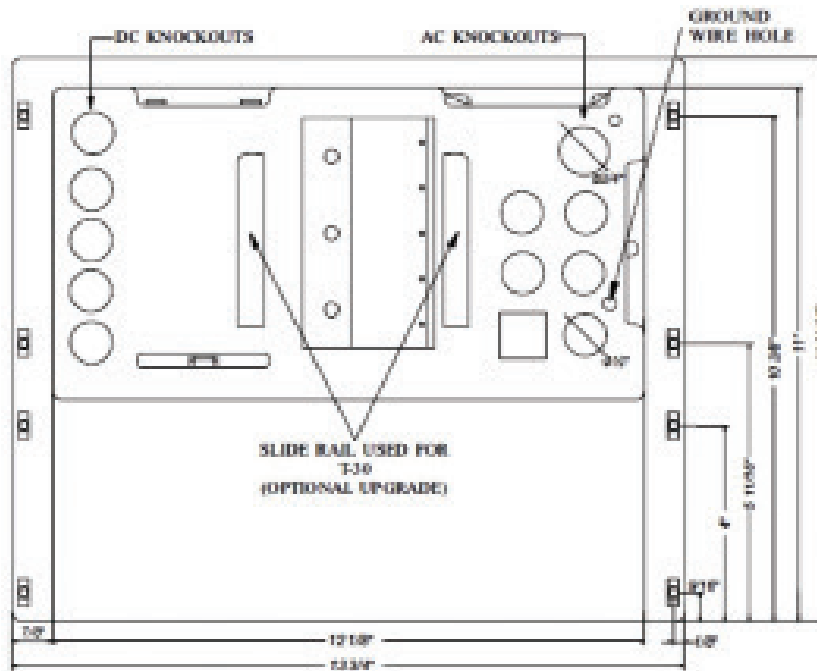

Figure 9

WFCO



TECHNOLOGIES

*Innovating the future of **RV POWER.***

2021 Aeroplex Drive, North
Elkhart, IN 46514
574-294-8997
www.wfcotech.com



Power Pros Technical Support
(574) 294-8997, Option 1
technicalsupport@wfcoelectronics.com

Warranty Information
Fax: (574) 294-8698
warranty@wfcoelectronics.com



