

# Product Manual



Innovating the future of **RV POWER.**

## EM-15 & EM-20 ENERGY MANAGEMENT SWITCH



Innovating the future of **RV POWER.**

• 2021 Aeroplex Drive, North Elkhart, IN 46514 • (574)-294-8997 • [www.wfcotech.com](http://www.wfcotech.com)

Rev: 4/24

# TABLE OF CONTENTS

SAFETY INFORMATION .....	3
<b>EM-15 / EM-20 OPERATION</b>	
Introduction .....	3
Product Description .....	3
Modes of Operation .....	4
EM-15 Power Relay Mode .....	4
EM-20 Power Relay Mode w/ Short Delay .....	5
EM-20 Power Relay Mode w/ Long Delay .....	5
EM-20 Logic Relay Mode w/ Short Delay .....	5
EM-20 Logic Relay Mode w/ Long Delay .....	6
EM-20 Remote Control .....	6
EM-20 Remote Panel Functions .....	7
<b>EM-15 / EM-20 INSTALLATION</b>	
Mounting the Enclosure .....	7
Mounting to a Wall or Floor .....	8
Mounting to a WF-89xxPEC .....	8
Mounting to a WF-85xx .....	8
Mounting the EM-20 Remote Control .....	9
<b>EM-15 / EM-20 WIRING</b>	
System Wiring Diagram .....	10
Internal EM-15 / EM-20 Wiring .....	11
Wiring Instructions .....	12
Air Conditioner Logic Wiring for the EM-20 .....	12
EM-15 / EM-20 TROUBLESHOOTING .....	13
SPECIFICATIONS .....	14
APPENDIX A .....	15
Timing Diagram Example .....	15
GENERAL COMPLIANCE INFORMATION .....	16
WARRANTY INFORMATION .....	16

### **!WARNING!**

Risk of Electrical Shock. Disconnect or isolate all power supplies before making electrical connections. More than one disconnection or isolation may be required to completely de-energize equipment. Contact with components carrying hazardous voltage can cause electric shock and may result in severe personal injury or death.

### **!IMPORTANT!**

All wiring must conform to local, national, and regional regulations. Use copper conductors only for all wire connections. Do not exceed the electrical ratings for the EM-15 / EM-20 or the equipment connected to it.

### **!CAUTION!**

This product should be installed by an experienced technician. CAUTION and care must be taken when servicing this equipment. To prevent severe shock or electrocution, consult your servicing dealer.

### **!WARNING!**

This unit employs components that can produce arcs or sparks. To prevent fire or explosion, do not install in compartments containing batteries or flammable materials (LP gas). This product is NOT ignition protected.

## **EM-15 / EM-20 OPERATION**

### **Introduction**

The EM-15 / EM-20 is a cost-efficient, energy management branch circuit expander. This product is designed to share the power from a single branch circuit between two mid-to-large power loads that normally require their own breaker. Potential applications include microwaves, fireplaces, hairdryers, water heaters, or even two air conditioners. RVs with two or more air conditioners frequently require 50A AC service; however, the EM-20 can be employed to manage two air conditioners in an RV with 30A service.

All WFCO products are designed to better meet the needs of RV owners while also making the job simpler for the installer. The EM-20 offers three flexible mounting options, as well as, a number of unique features – like four basic power modes and a remote panel for manual energy management – making it easy for RV owners to assign energy to the circuit they need at any particular time. The EM-15 also offers three flexible mounting options, and can quickly be utilized wherever there is a need for energy management on a 15A branch circuit.

### **Product Description**

The EM-15 / EM-20 is an Energy Management Switch designed to be used in recreational vehicles to share the power from a single 15A / 20A branch circuit between two mid- to large-loads. The device applies power to both loads until the total loaded current exceeds approximately 13.5A / 18A. It then cuts the power to the secondary load to prevent the 15A / 20A circuit breaker from tripping while maintaining the primary load. The secondary load will be restored automatically when the total loaded current drops below a preset level (~5A).

The EM-15 / EM-20 default primary (priority) branch is Circuit A. The secondary load (which may be shut off) shall be wired to Circuit B.

## Modes of Operation

### EM-15 Power Relay Mode:

The EM-15 has a single mode of operation for the following application: sharing the power between two appliances on a 15A breaker (for example: a microwave and a fireplace or water heater).

This mode of operation functions as follows: Power is applied to the EM-15. After a short delay of approximately 4 seconds, power will be supplied to both the primary and secondary circuits. The EM-15 constantly monitors current levels, and will shut down the secondary circuit once levels reach approximately 13.5A. Once the current levels have dropped below approximately 5A, power will return to the secondary circuit.

### EM-20 Modes:

The EM-20 has 4 basic modes of operation.

1. Power Relay Mode w/ Short Delay
2. Power Relay Mode w/ Long Delay
3. Logic Relay Mode w/ Short Delay
4. Logic Relay Mode w/ Long Delay

The mode can be switched using the red & white switch located inside the EM-20. If the mode is changed it will require the power to be cycled OFF then ON before the EM-20 will recognize the new mode. The EM-20 implements these modes through 4 different internal relays (2 high current power relays and 2 low current logic relays).

### Power Relay vs Logic Relay:

In *Power Relay Mode*, when faced with an over current condition, the power for the entire secondary circuit shuts OFF.

In *Logic Relay Mode*, when faced with an over current condition, the power for the secondary circuit always remains ON, while a “logic relay” switches states.

*Logic Relay Mode* expects the load to manage its’ own power. This is a very important distinction! *Logic Relay Mode* shall NOT be used unless the load is designed to be used with an energy management system, and has inputs which expect a simple, low power relay switch closure.

### Long Delay:

When an air conditioner is in operation, its compressor circulates refrigerant under high pressure. Once OFF, it will take 2-3 minutes for this high pressure to equalize. For this reason, the EM-20 adds an off-time delay of approximately 3 minutes. This delay will prevent “short cycling” the compressor and will also be observable during the initial power ON sequence of the EM-20.

#### EM-20 Power Relay Mode w/ Short Delay:



This mode shall be used when two appliances (without compressors) are sharing the same circuit breaker (for example: a microwave and a fireplace or water heater).

Power is applied to the EM-20. After a short delay of approximately 4 seconds, power will be supplied to both the primary and secondary circuits. The EM-20 constantly monitors current levels, and will shut down the secondary circuit once levels reach approximately 18A. Once the current levels have dropped below approximately 5A, power will return to the secondary circuit.

#### EM-20 Power Relay Mode w/ Long Delay:



This mode shall be used when attempting to combine two loads with compressors that are not set up to use logic relays.

Power is applied to the EM-20. After a delay of approximately 3 minutes, power will be supplied to both the primary and secondary circuits. The EM-20 constantly monitors current levels, and will shut down the secondary circuit once levels reach approximately 18A. The "OFF time delay timer" is then triggered. Once the timer has expired, and the current levels have dropped below approximately 5A, power will return to the secondary circuit.

#### EM-20 Logic Relay Mode w/ Short Delay:



This mode shall be used when attempting to combine two air conditioners on one 20A breaker. These air conditioners shall be equipped with energy management system inputs and have the ability to use logic relays for compressor control. THIS MODE SHALL ONLY BE SELECTED IF THE AIR CONDITIONER CONTROL CIRCUITRY PROVIDES THE NECESSARY OFF-TIME DELAY ITSELF TO PREVENT SHORT CYCLING THE COMPRESSOR.

Power is applied to the EM-20. After a short delay of approximately 4 seconds, power will be supplied to both the primary and secondary circuits. Both power relays will continue to stay on for as long as there is power applied to the EM-20. The control is performed through the logic relays. The EM-20 constantly monitors current levels, shutting down (energizing) the secondary logic relay when levels reach approximately 18A. Once the current levels have dropped below approximately 5A, the secondary logic relay will be de-energized.

### EM-20 Logic Relay Mode w/ Long Delay:



This mode shall be used when attempting to combine two air conditioners on one 20A breaker. These air conditioners shall be equipped with energy management system inputs and have the ability to use logic relays for compressor control. THIS MODE SHALL BE SELECTED IF THE AIR CONDITIONER CONTROL CIRCUITRY DOES NOT PROVIDE THE NECESSARY OFF-TIME DELAY ITSELF TO PREVENT SHORT CYCLING THE COMPRESSOR.

Power is applied to the EM-20, after a short delay of approximately 4 seconds, power will be supplied to both the primary and secondary circuits (also triggering the “OFF time delay timer” of approximately 3 minutes) and the logic relays will be energized. Both power relays will continue to stay on for as long as there is power applied to the EM-20. The control is performed through the logic relays. Once the “OFF time delay timer” has expired the EM-20 de-energizes the logic relays, and will constantly monitor current levels, shutting down (energizing) the secondary logic relay when levels reach approximately 18A. The “off time delay timer” is then triggered. Once the timer has expired, and the current levels have dropped below approximately 5A, the secondary logic relay will be de-energized.

### EM-20 Logic Relay Operation Detail:

The EM-20 logic relays provide dry relay contacts (simple low current switch closure) and operate as follows: Under normal operation with both circuits ON, the logic relays will be de-energized (relay common connected to the normally closed contacts). When the total current exceeds the upper trip limit, the logic relay for the secondary channel is energized (relay common connected to the normally open contacts).

For wiring air conditioners with energy management logic capabilities please refer to the *Air Conditioner Logic Wiring* section.

## **EM-20 Remote Control**



The EM-20 remote control allows the user to easily specify which circuit should always remain ON, in the event that appliances on both branches require too much power. The LEDs indicate which branch will be Primary, allowing the other branch to be shut OFF. Pushing the button (until a soft click is felt) will change the preference. The LED for the circuit indicating the primary branch will change immediately as soon as the button is pressed. The background relay activation will occur after a short delay of approximately 4 seconds.

## EM-20 Remote Panel Functions

Function: Set Circuit Priority

Circuit A LED is Illuminated OR NO Remote Installed	Circuit B LED is Illuminated
Circuit A is always available	Circuit B is always available
Circuit B drops out on over-current condition	Circuit A drops out on over-current condition

## EM-15 / EM-20 INSTALLATION

### Mounting the Enclosure

The EM-15 / EM-20 has primarily been designed for three different mounting configurations. A simple rotation of the mounting bracket facilitates the different configurations.

1. Wall/Floor Mounting.
2. Back of WFCO WF-89xxPEC Power Centers.
3. Back of WFCO WF-85xx Power Centers.

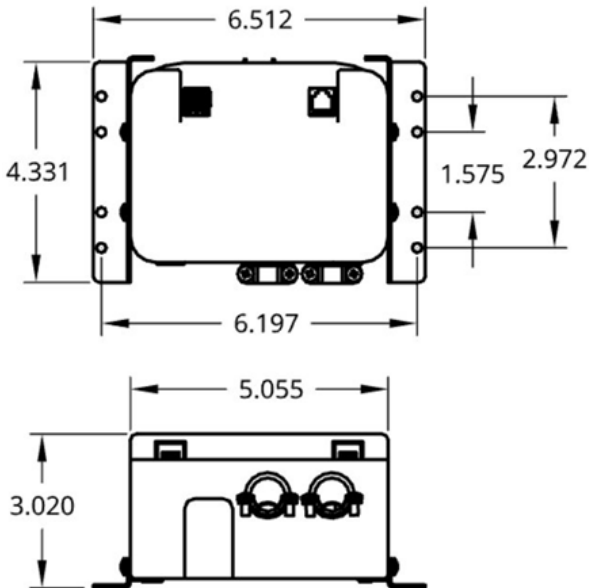

## Mounting to a Wall or Floor

Bracket Position:

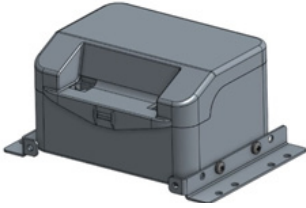

## Mounting to a WF-89xxPEC

Bracket Position:

The brackets will slide into the slots on the back of the power center, with the screws in the top of the power center going through the bracket to hold it in place.

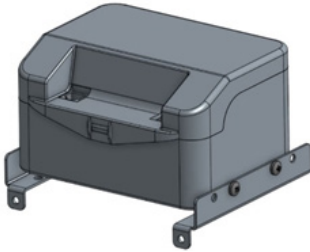

## Mounting to a WF-85xx

Bracket Position:

No bracket is necessary. The mounting holes for the bracket on the EM-15 / EM-20 have corresponding holes on the back of the 85xx series power centers. Remove the brackets and use the bracket screws to mount the EM-15 / EM-20 directly to the back of the power center.

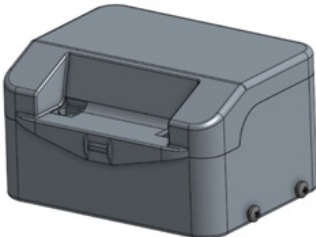



## Mounting the EM-20 Remote Control

The remote-control panel should be mounted in an easily accessible location. The supplied remote cable shall be routed from the remote location to the EM-20.

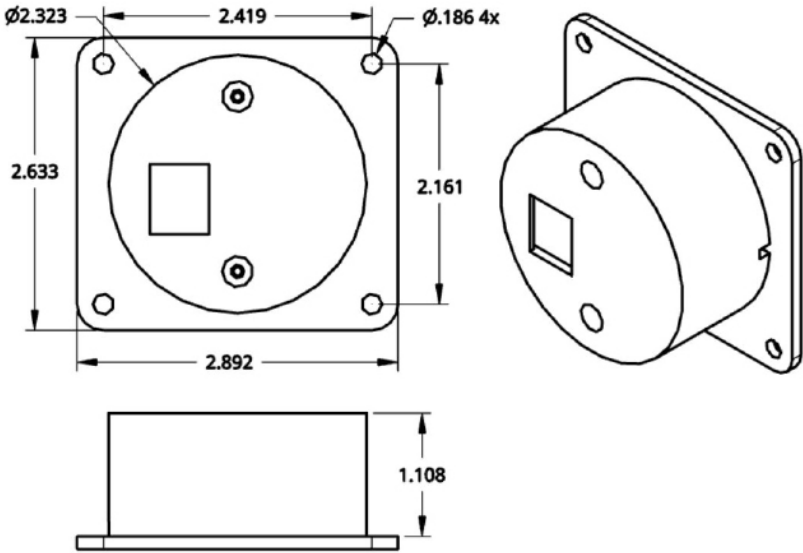

# EM-15 / EM-20 WIRING

## System Wiring Diagram

For 20A applications, use 12AWG copper conductors only. For 15A applications, use 14AWG copper conductors only.

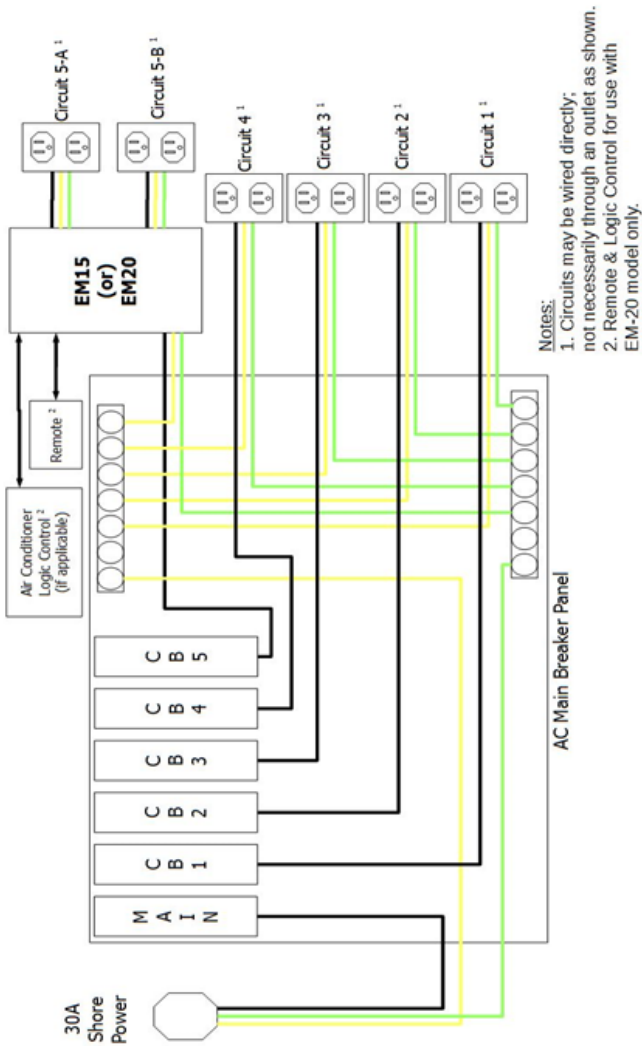

**System Wiring Diagram**

## Internal EM-15 / EM-20 Wiring

For 20A applications, use 12AWG copper conductors only. For 15A applications, use 14AWG copper conductors only.

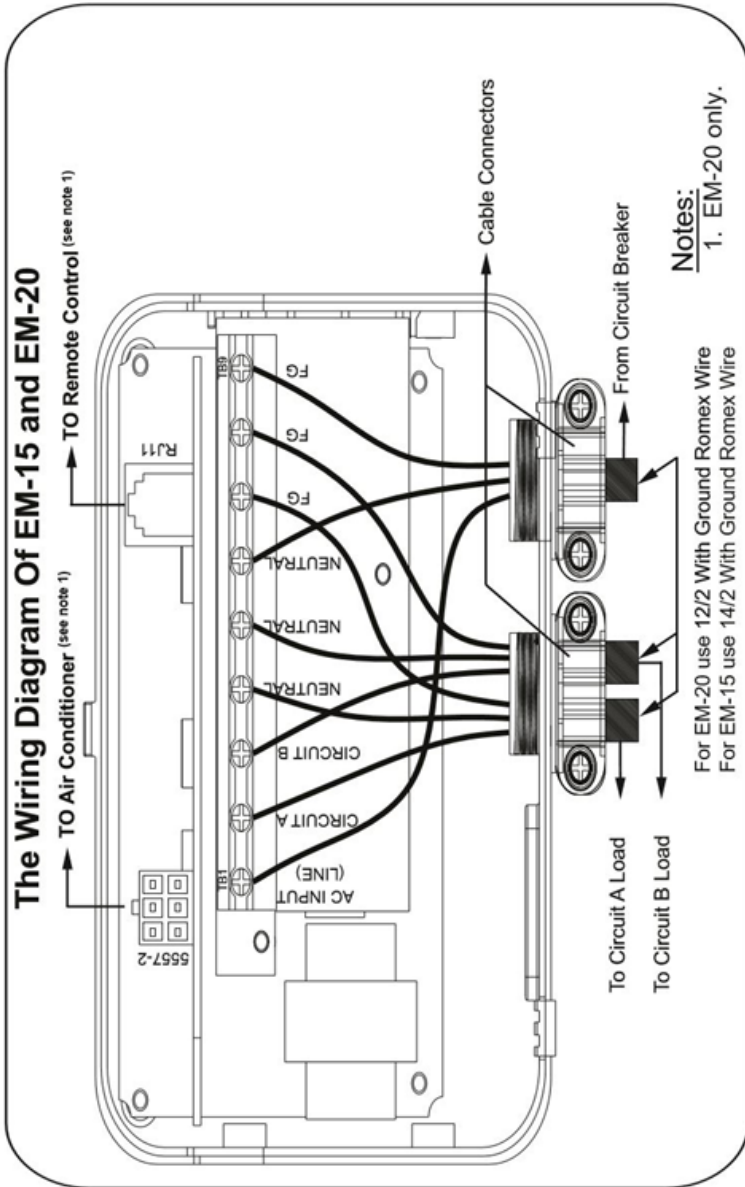

## Wiring Instructions

For 20A applications, use 12AWG copper conductors only. For 15A applications, use 14AWG copper conductors only. All wiring shall meet local codes/standards and be performed by qualified personnel.

- If the remote panel is NOT used or NOT available, the priority circuit shall be connected to circuit A.
- Remove the lid and put it in a temporary safe place.
- Feed Romex cable from the 15A (for EM-15) or 20A (for EM-20) circuit breaker into the centrally-located cable clamp.
  - Connect Black wire to TB1 (AC Input / Line).
  - Connect White wire to TB4 (Neutral).
  - Connect Ground wire to TB7 (FG).
  - Fasten all terminals down (suggested torque 7 in-lbs).
  - Secure the AC Power wire with the two-screw clamp connector.
- Feed 2 Romex cables from the Circuit A and Circuit B into the cable clamp near the end.
  - Connect the Circuit A Black wire to TB2 (Circuit A).
  - Connect the Circuit A White wire to TB5 (Neutral).
  - Connect the Circuit A Ground wire to TB8 (FG).
  - Connect the Circuit B Black wire to TB3 (Circuit B).
  - Connect the Circuit B White wire to TB6 (Neutral).
  - Connect the Circuit B Ground wire to TB9 (FG)
  - Fasten all terminals down (suggested torque 7 in-lbs).
  - Secure the wires for Circuit A and Circuit B in the two-screw clamp connector.
- Put lid back on the EM-15 / EM-20.
- For the Remote: Mount the Remote Control in a convenient location. Route and connect the remote cable into the 6-pin phone connector on both the EM-20 and the remote.

## Air Conditioner Logic Wiring for the EM-20

This section shall be used if you have two air conditioners designed to be used with an energy management system. For best operation, make sure the air conditioner fan is set to auto.

EM-20 Molex 5569 Pin #	EM-20 Molex 5569 Wire Color	Description	Air Conditioner Connections
1	BLK	AC1-NC	
2	WHT	AC1-COM	AC1-Load Shed
3	BLU	AC1-NO	AC1-Load Shed
4	RED	AC2-NC	
5	ORG	AC2-COM	AC2-Load Shed
6	YEL	AC2-NO	AC2-Load Shed

The EM-20 logic relays provide dry relay contacts and operate as follows: Under normal operation with both circuits ON, the logic relays will be de-energized (relay common connected to the normally closed contacts). When the total current exceeds the upper trip limit, the logic relay for the secondary channel is energized (relay common connected to the normally open contacts).

The air conditioner logic wiring chart assumes the air conditioner expects a relay contact closure when the compressor should be off. Please refer to the air conditioner manufacturers manual for more information.

## EM-15 / EM-20 TROUBLESHOOTING

Symptom	Potential Reason	Action to Perform
No power on both circuits.	<ol style="list-style-type: none"> <li>1. No power to EM-##</li> <li>2. EM-## is in "OFF-time delay"</li> </ol>	<ol style="list-style-type: none"> <li>1. Verify that the RV has power &amp; reset the EM-## breaker</li> <li>2. Power the EM-## for 5 minutes &amp; verify operation</li> </ol>
No power on one circuit (the other circuit is OK).	<ol style="list-style-type: none"> <li>1. Load may not be turned ON</li> <li>2. EM-## may have turned off 1 circuit because of current draw</li> <li>3. EM-## may be in "OFF-time delay"</li> </ol>	<ol style="list-style-type: none"> <li>1. Turn ON both loads</li> <li>2. Turn OFF power to the operating circuit appliance, wait 5 minutes &amp; verify operation of the other circuit appliance</li> <li>3. Power the EM-## for 5 minutes &amp; verify operation</li> </ol>
Both circuits are on at the same time.	<ol style="list-style-type: none"> <li>1. Total current draw may be below the trip point</li> <li>2. EM-## may be in the wrong mode</li> </ol>	<ol style="list-style-type: none"> <li>1. Turn both appliances on high &amp; verify that the circuit breaker doesn't trip</li> <li>2. Refer to qualified service technician for mode verification</li> </ol>
No LED lights on the remote.	<ol style="list-style-type: none"> <li>1. No power to EM-##</li> <li>2. Bad connection on the remote cable</li> <li>3. Defective remote</li> </ol>	<ol style="list-style-type: none"> <li>1. Verify that the RV has power &amp; reset EM-## breaker</li> <li>2. Replace remote cable</li> <li>3. Replace remote</li> </ol>
Switch doesn't work on the remote.	<ol style="list-style-type: none"> <li>1. EM-## may be in "OFF-time delay"</li> <li>2. Defective remote</li> </ol>	<ol style="list-style-type: none"> <li>1. Power the EM-## for 5 minutes &amp; verify operation</li> <li>2. Replace remote</li> </ol>

Refer to the Troubleshooting Chart on the next page.

## Troubleshooting Chart

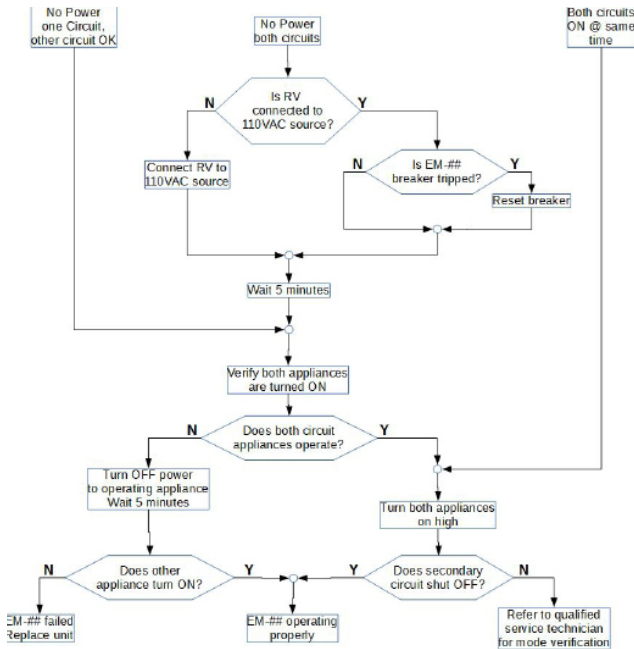

## Specifications

Model:	EM-15 & EM-20
Power:	120V / 60Hz
Power Relay:	2; Contact Rating: 30A / 250VAC; Coil Rating: 12VDC
Logic Control Relay (EM-20 ONLY):	2; SPDT Contact Rating: 3A / 250VAC; Coil Rating: 12VDC
Delay Time:	3 minute resume delay time for air conditioner protection (EM-20 ONLY); N/A for general appliances
Enclosure:	Fire-retardant reinforced plastic
Dimensions:	128 x 112 x 73 mm / 5.04 x 4.41 x 2.9 in (L x W x H)
Weight:	0.55 kgs / 1.21 lbs
Mounting:	Wall/Floor mounting or mount directly to the back of WFCO Power Centers (8900 or 8500 Series)
Remote Switch (EM-20 ONLY):	12 ft long wire and RJ11 connector; 1 switch to set circuit priority; 2 LEDs to indicate which circuit is priority
AC Connections:	9P terminal block for 12 AWG / 14 AWG wire; Suggested 7 in-lb torque
Safety:	CETL / UL 916 + CSA C22.2 NO. 205

# APPENDIX A

## Timing Diagram Example

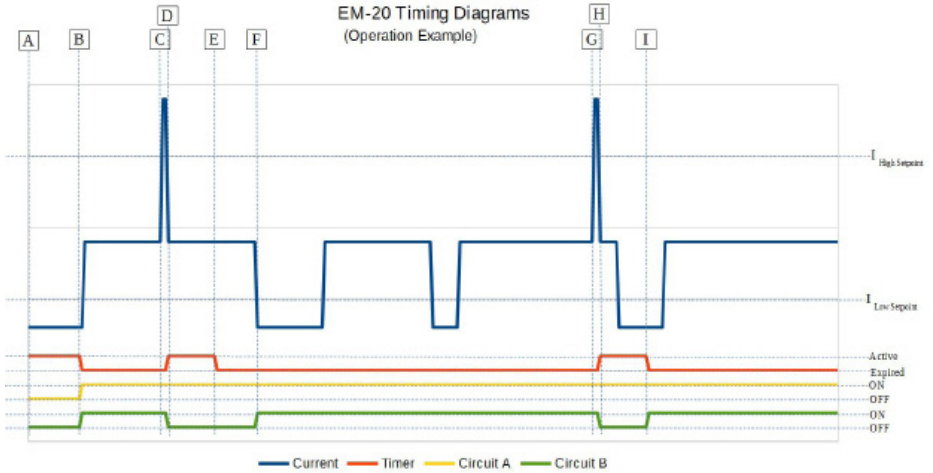

	Description	Circuit A	Circuit B
A:	1. Power ON 2. <b>Start Timer</b>	OFF	OFF
A-B	AC mode: ~3 minutes General mode: ~3 seconds	OFF	OFF
B:	1. Timer Expires 2. Start Both Circuits	ON	ON
B-C	Indeterminate time	ON	ON
C:	Current > High Limit	ON	ON
C-D	< ~4 seconds	ON	ON
D:	1. Shed non-priority circuit 2. <b>Start Timer</b>	ON	OFF
D-E	AC mode: ~3 minutes General mode: ~3 seconds	ON	OFF
E:	Timer Expires	ON	OFF
E-F	Indeterminate time	ON	OFF
F:	1. Current < Low Limit 2. Restart shed circuit	ON	ON
F-G	Indeterminate time	ON	ON
G:	Current > High Limit	ON	ON
G-H	< ~4 seconds	ON	ON
H:	1. Shed non-priority circuit 2. <b>Start Timer</b>	ON	OFF
H-I	AC mode: ~3 minutes General mode: ~3 seconds	ON	OFF
I:	1. Timer Expires 2. Restart shed circuit	ON	ON

**NOTES:**

1. Priority = Circuit A
2. This example is intended to show the relationship between current, timer, and channel status only.

## GENERAL COMPLIANCE INFORMATION

### AGENCY Listings

#### **UL:**

The EM-15 / EM-20 Series units are ETL listed for the United States and Canada.

#### **FCC Compliance Class B:**

NOTE: This equipment has been tested and found to comply with the limits for a Class B digital device, pursuant to Part 15 of the FCC Rules. These limits are designed to provide reasonable protection against harmful interference when the equipment is operated in a commercial environment. This equipment generates, uses, and can radiate radio frequency energy, and if not installed and used in accordance with the instruction manual, may cause harmful interference to radio communications. Operation of this equipment in a residential area is likely to cause harmful interference in which case the user will be required to correct the interference at his own expense.

## CONSUMER LIMITED WARRANTY

### For WFCO Electronics Products

WFCO extends, to the original owner, a Two Year Limited Product Warranty. This warranty is in effect from the date of original purchase for a period of two (2) years. This limited warranty is extended specifically for and is limited to Recreational Vehicle application and is only valid within the continental United States, Alaska, Hawaii and the Provinces of Canada.

WFCO warrants, to the owner, that its products are free from defects in material and workmanship under normal use and service based on its intended use and function. This warranty is limited to the repair or replacement, at WFCO's discretion, of any defective parts or defective assembly. Any implied warranties of merchantability or fitness for intended use are limited in duration unless applicable State Law provides otherwise. You may have other rights as specified by each individual state.

#### **EXCLUSIONS and LIMITATIONS**

The OEM warranty specifically does not apply to the following:

- Any WFCO product that has been repaired or altered by an unauthorized person;
- Any damage caused by misuse, faulty installation, testing, negligence, accident or any WFCO product installed in a commercial vehicle;
- Any WFCO product, whose serial number has been defaced, altered or removed;
- Any WFCO product, whose installation has not been in accordance to the WFCO written instructions;
- Any consequential damages arising from the loss of use of the product including but not limited to: inconvenience, loss of service, loss of revenue, loss or damage to personal property, cost of all services performed in removing or replacing the WFCO product. Specifications are subject to change without notice or obligation.
- Any WFCO Electronics products sold through unauthorized Internet sources (Example: eBay) will be excluded from all warranty coverage offered by Arterra Distribution / WFCO.



## **CONSUMER WARRANTY CLAIM PROCEDURE**

After it has been determined that a WFCO product is defective, an RGA number will be required before it can be returned. The RGA number can be requested by completing the Warranty Information Fax Sheet & Troubleshooting Form found at [www.wfcoelectronics.com](http://www.wfcoelectronics.com). Once the forms have been completed, email this form along with Proof of Purchase to [warranty@wfcoelectronics.com](mailto:warranty@wfcoelectronics.com) or fax both forms to the Warranty Department (574)-294-8698. After receipt of the forms, an RGA number will be issued. This number shall appear on all correspondence with warranty service. Upon validation of the warranty, WFCO shall replace or repair the product with a like product. The RGA number shall be placed on the outside of the carton used to return the product for ease of identification. Do not mark directly on the product. The product must be packaged properly to avoid further product damage which could cause a non-warrantable condition.

## **WARRANTY ASSISTANCE**

The consumer may contact the selling Dealer or OEM for warranty assistance. The OEM may contact Arterra Distribution, the RV Division of the WFCO Group, at Phone: (877) 294-8997 or Fax: (574) 294-8698.



*Innovating the future of **RV POWER.***

**2021 Aeroplex Drive, North  
Elkhart, IN 46514  
574-294-8997  
[www.wfcotech.com](http://www.wfcotech.com)**

---



EXPERT PRODUCT SUPPORT

**Power Pros Technical Support**  
**(574) 294-8997, Option 1**  
[technicalsupport@wfcocoelectronics.com](mailto:technicalsupport@wfcocoelectronics.com)

**Warranty Information**  
**Fax: (574) 294-8698**  
[warranty@wfcocoelectronics.com](mailto:warranty@wfcocoelectronics.com)