

Product Manual



*Innovating the future of **RV POWER.***

WF-5118 / WF-5120 PURE SINE WAVE INVERTER



*Innovating the future of **RV POWER.***

• 2021 Aeroplex Drive, North Elkhart, IN 46514 • (574)-294-8997 • www.wfcotech.com

Rev: 5/24

GENERAL INFORMATION.....	1
WF-5118/5120 PRODUCT FEATURES	2
WF-5118/5120 SAFETY FEATURES	2
OPERATIONAL FEATURES	
Front Panel Interface	4
Rear Panel Interface	4
AC Pass-Through Mode	4
Inverter Power Mode	5
Diagnostic Display Panel	5
Remote Switch Panel	5
TROUBLESHOOTING INSTRUCTIONS	
Reverse Polarity Protection	6
DC Voltage Check	6
Pass-Through	6
Remote Switch	6
Remote Switch LEDs	7
No Generated Power Output	7
Troubleshooting Flow Chart - No Pass-Through	8
Troubleshooting Flow Chart - No Generated Output	9
GENERAL COMPLIANCE INFORMATION	
Agency Listings	12
INSTALLATION INSTRUCTIONS	
Mounting the Enclosure	10
AC Ground Bonding	10
Neutral Bonding	10
AC System Wiring.....	11
DC Wiring Connections	12
Other Connections	13
SPECIFICATIONS	14
WARRANTY INFORMATION	15
DIMENSIONAL DRAWINGS	16

WARNING

Risk of Electrical Shock. Disconnect or isolate all power supplies before making electrical connections. More than one disconnection or isolation may be required to completely de-energize equipment. Contact with components carrying hazardous voltage can cause electric shock and may result in severe personal injury or death.

IMPORTANT

All wiring must conform to local, national, and regional regulations. Use copper conductors only for all wire connections. Do not exceed the electrical ratings for the WF-5118/5120 Inverters or the equipment connected to it.

CAUTION

This product should be installed by an experienced technician. CAUTION and care must be taken when servicing this equipment. To prevent severe shock or electrocution, consult your servicing dealer.

WARNING

This unit employs components that can produce arcs or sparks. To prevent fire or explosion, do not install in compartments containing batteries or flammable materials (LP gas). This product is NOT ignition protected.

CAUTION

To prevent fire, do not cover or obstruct front cover ventilation openings. For continued protection against risk of fire or electric shock, replace faulty DC fuses and AC breakers with ones of the same type and ratings as are installed.

CAUTION

When using a battery with the WF-5118/5120 Inverters, follow battery maintenance procedures. Check the fluid level in any battery connected to RV charging system on a monthly basis.

The WF-5118/5120 Inverters are standalone power inverters with AC Pass-Through suitable for use in RV, Marine, and other applications where a True Sine Wave 115 VAC voltage is required. The WF-5118 inverter will produce 1800 Watts of AC power. The WF-5120 inverter will produce 2000 Watts of AC power.

When 115 VAC utility power is applied to the WF-5118/5120 Inverters through the Shore cord, 115 VAC will pass straight through to the connected load. Should utility power be cut off, the WF-5118/5120 Inverters automatically switch to invert mode, providing clean 115 VAC to the connected load. When utility power is reapplied, the WF-5118/5120 switches back to the Pass-Through mode.

The WF-5118/5120 Inverters require 12 VDC (nominal) input from the house battery to operate in the inverting mode. For Pass-Through mode, a convenient internal wiring box is located on the rear panel, along with the hardwire output.

Please read all instructions and cautionary statements in this manual before installation and use of the WF-5118 and WF-5120 Inverters.

WF-5118/5120 INVERTER PRODUCT FEATURES

- Advanced Microprocessor Control Circuit Design
- High-Frequency Switching Mode Power Topology
- THD < 3%; Pure Sine-Wave Output Waveform
- High Surge Current Walk-In Capability (3:1 Crest Factor)
- High Overload Capability
- Rear Panel Mounted Resettable Circuit Breaker
- $\pm 3\%$ Regulated AC Output Voltage
- Better than 80% System Efficiency
- Automatic Utility Bypass Transfer Switch
- LED Status Display with Level Indication of Battery & Load
- Output Overload and Short-Circuit Protection
- Over Temperature Protection
- Over/Under DC Input Voltage Protection
- Battery Input Reverse Polarity Protection
- Two-Stage Low Battery Protection
- Remote On/Off Control & Status Display Panel with 32-ft. Cable
- Listings Include UL 458 and FCC Class B
- 2-Year Limited Warranty

WF-5118/5120 INVERTER SAFETY FEATURES

DC Reverse-Polarity Battery Protection

The WF-5118/5120 Inverters are protected from reverse battery connection by fuses located inside the enclosure. This feature prevents permanent damage to the inverter from a battery connected into the circuit backwards. Blown reverse polarity fuses are not replaceable by the user. The fuses are designed to protect RVs from catastrophic damage; once the fuses are blown, the inverter must be replaced.

Over-Temperature Protection

If the internal temperature of the inverter exceeds a critical point, it will shut down and the Red Fault LED on the front panel and remote switch will illuminate. This protects the unit from excessive heat that may damage sensitive components. Remove or reduce the AC load and cycle the power button to restart the unit.

Electronic Current Limiting

When the WF-5118/5120 Inverter is in the inverting mode, should the AC output current exceed the maximum rating, the unit will shut down and the Red Fault LED on the front panel and remote switch will illuminate. If this occurs, remove or reduce the connected load. Cycle the power button on the front panel to restart the inverter.

Short-Circuit Protection

Should a short circuit occur in the inverter circuit when in Pass-Through mode, the circuit breaker supplying AC power to the inverter, or the circuit breaker located on the back panel of the inverter, may trip. If the inverter is in inverting mode, the inverter's internal protection circuitry will shut the unit down and the Red Fault LED on the front panel and remote switch will illuminate. Short-circuit conditions are **dangerous** and may require an inspection of the RV by a qualified service technician.

Over/Under Input Protection

The WF-5118/5120 Inverters have a DC input range of 10-15 VDC (nominal). If the battery input should fall outside this range, the inverter will shut down to protect the circuitry.

AC Circuit Breaker

The AC output of the WF-5118/5120 Inverters is protected by a resettable circuit breaker (see Figure 1 below). The WF-5118 and WF-5120 models have a 20A/120 VAC circuit breaker located on the upper left side of the rear panel.

The breaker may trip in a high current situation. Should a breaker trip, reduce or remove the connected AC load and reset the circuit breaker. Restart the inverter and check for proper operation.

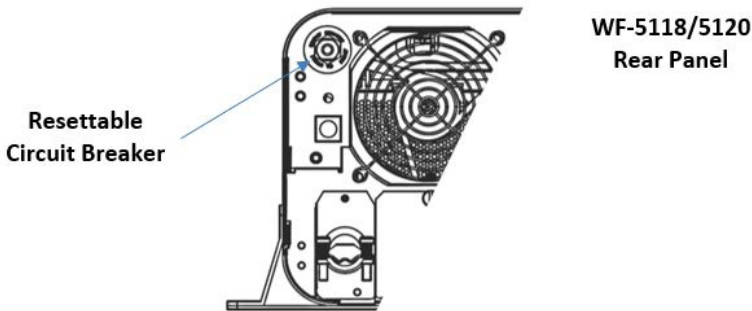

Internal Cooling Fan

The WF-5118/5120 Inverters are equipped with 4 DC brushless fans to provide cooling for the circuitry. Two fans are located on the rear panel and two fans are located on the front panel.

CIRCUIT PROTECTION

WF-8500 Series Fuses and Breakers

OPERATIONAL FEATURES

Front Panel Interface

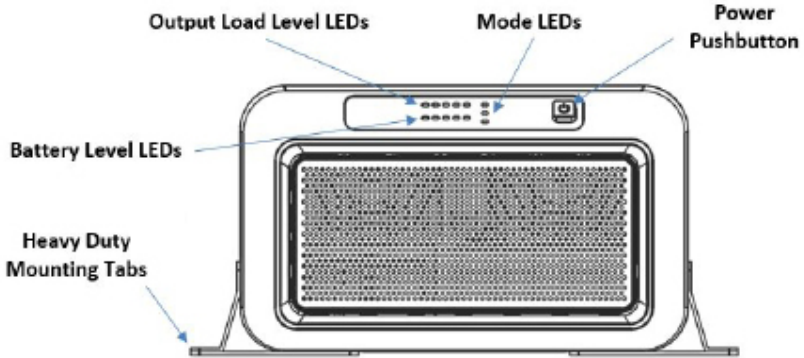

Rear Panel Interface

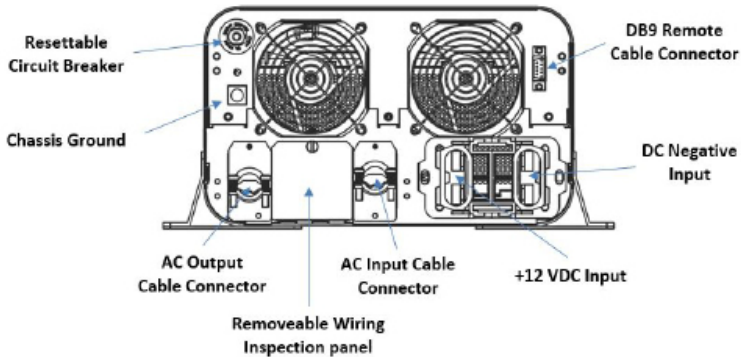

Inverter Operation

AC Pass-Through Mode

When incoming AC power or inverter produced power is available, the transfer switch is designed to pass this voltage straight through to the inverter output. The WF-5118/5120 Inverter power switch does not have to be in the ON position for Pass-Through to work. This mode will also work with or without a battery attached. NOTE: if the power switch is in the ON position and incoming power is lost, the WF-5118/5120 Inverter will switch to invert mode to provide AC voltage to connected loads.

Inverter Power Mode

When incoming AC power is not available, and the Power Pushbutton is in the ON position, the inverter will produce AC voltage at the output.

Diagnostic Display Panel

The WF-5118 and WF-5120 Inverters have front panel LEDs to indicate the output load being supplied, current battery level, and operational mode of the inverter. Both the output load level and battery level are displayed in four 25% increments, from 25% to 100%.

Percentage	25%	50%	75%	100%
Battery	>10.5 VDC	>11 VDC	>11.7 VDC	>12.5 VDC
WF-5118 Load	3.75 A	7.5 A	11.25 A	15.0 A
WF-5120 Load	4.17 A	8.34 A	12.5 A	16.67 A

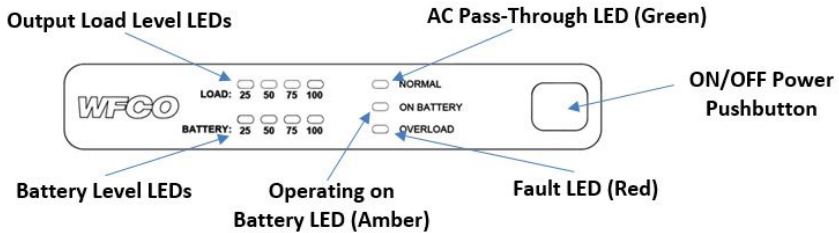

Remote Switch Panel

The WF-5118/5120 Inverters have a remote switch panel that provide status information and ON/OFF control of the unit from a remote location. The WF-5118 and WF-5120 remote can be located up to 32.8' (10m) away from the main inverter unit. In addition to the ON/OFF power pushbutton, the faceplate mimics the status LEDs found on the main inverter units front panel. See the *Diagnostic Display Panels* section above for a description of the status LEDs. NOTE: As above, the main inverter unit's power pushbutton must be in the OFF position for the remote panel to function.

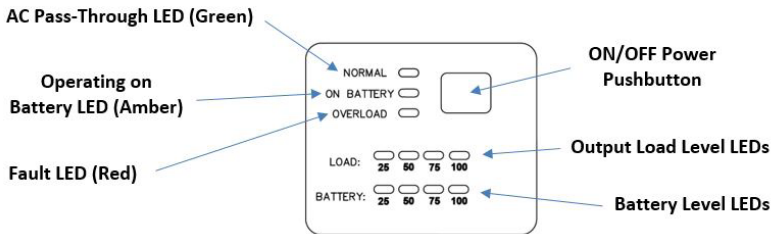

TROUBLESHOOTING INSTRUCTIONS

Troubleshooting the 5118/5120 Inverters

Reverse Polarity Fuses

Check to make sure the DC cables are connected to the proper input lug. The Positive (+) DC cable MUST be connected to the Red or (+) lug on the back of the inverter. The Negative (-) DC cable MUST be connected to the Black or (-) lug on the back of the inverter. If these cables are connected backwards either at the inverter or at the battery, the internal Reverse Polarity fuses will blow. **IMPORTANT:** These fuses protect the inverter from damage in the event that the RV battery is accidentally connected in reverse. A reversed battery connection, even if for only a second, will cause these fuses to blow. These internal fuses are non-replaceable.

Check DC Input Voltage

For proper operation of the inverter, the WF-5118/5120 Inverters require a DC input between 10-15 VDC (nominal). If the battery voltage is below 11.0 volts, a Low Battery symbol will appear on the center display (see Figure 4). Recharge the battery for continued operation. If the voltage is above 15 VDC, as can happen with some tow vehicle alternators, the WF-5118/5120 Inverter will shut down to protect the internal circuitry.

Inverter Has No Pass-Through

Check the circuit breaker located on the WF-5118/5120 Inverter's rear panel. If the breaker is not tripped, check to make sure the inverter is receiving 115 VAC. NOTE: When the WF-5118/5120 Inverter is in Pass-Through mode, the Normal (Green) LED on the front panel will be illuminated to indicate the presence of 115 VAC.

Remote Switch Will Not Turn Inverter ON/OFF

The remote switch will only work if the main Power Pushbutton located on the WF-5118/5120 Inverter's front panel is in the OFF position. If the remote switch does not turn the inverter ON/OFF, check the remote switch cable that runs between the rear panel of the inverter to the back of the remote switch. Make sure the female DB9 connector is fully seated into the male DB9 connector on the rear panel. Tighten the two thumbscrews on either side of the cable connector. On the opposite end of the cable, make sure the 10-pin single row connector is fully seated into the back of the remote switch.

If the remote switch will not turn the inverter ON/OFF, replace the remote switch and check for proper operation. If the remote switch will not work, replace the connecting cable.

Remote Switch LEDs Do Not Mimic the Front Panel LEDs

The remote switch LEDs should display the same status information that is on the WF-5118/5120 Inverter front panel. Check the remote switch cable that runs between the rear panel of the inverter to the back of the remote switch. Make sure the female DB9 connector is fully seated into the male DB9 connector on the rear panel. Tighten the two thumbscrews on either side of the cable connector. On the opposite end of the cable, make sure the 10-pin single row connector is fully seated into the back of the remote switch.

If the remote switch does not display the proper information, replace the remote switch and check for proper operation. If the remote switch will not work, replace the connecting cable.

Unit Has Pass-Through but Nothing Works (Power Button in ON Position)

Make sure the WF-5118/5120 Inverter's Power Pushbutton is in the OFF position. Disconnect the Negative (White) wire from the DC input lugs at the rear panel. Let the unit stand idle for approximately 5 minutes so the internal circuitry can normalize. Reconnect and securely tighten the Negative (White) wire. Push the Power Pushbutton to the ON position. The unit should work normally.

Contact the WFCO Power Pro's at WFCO Technologies, at: (574) 294-8997



Troubleshooting Guide for Shore- Power Connection WF- 5118 & WF-5120: 1800 & 2000 Watt Pure Sine Wave Inverters

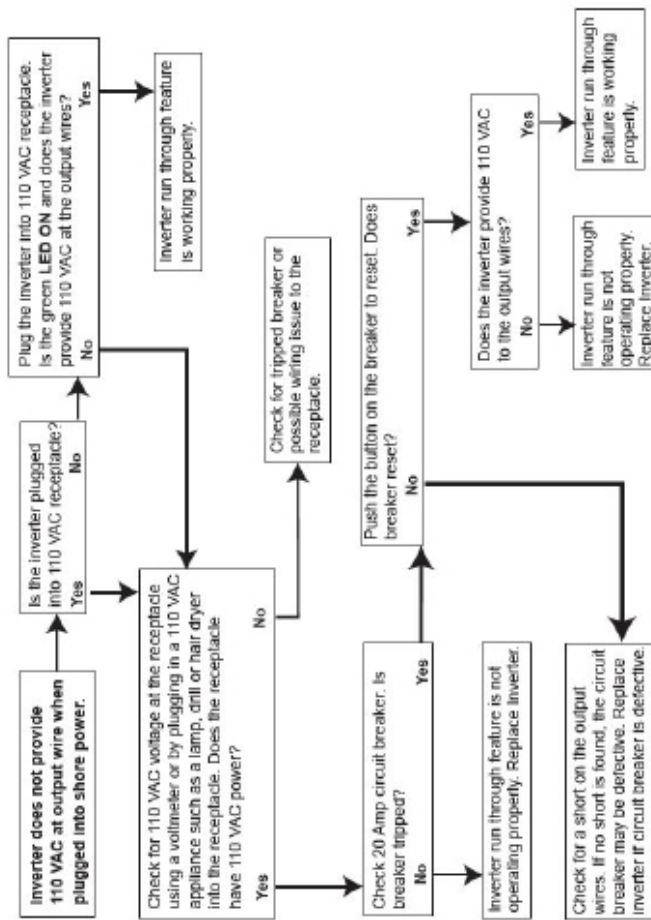

Remote Operation

The remote feature of the inverter provides a method to turn the inverter ON or OFF from a remote location. In order for this feature to work properly, the ON/OFF button on the front of the inverter needs to be in the OFF (out) position. When turning the inverter ON from the remote location a green LED on the remote will light, indicating that the inverter is ON. Should the green LED stay on constantly but the remote button has no function, check the ON/OFF button on the front of the inverter, verifying that the ON/OFF button is in the OFF (out) position.

Troubleshooting Guide for Power Inverting from the Battery

WF-5118 & WF-5120:

1800 & 2000 Watt Pure Sine Wave Inverters

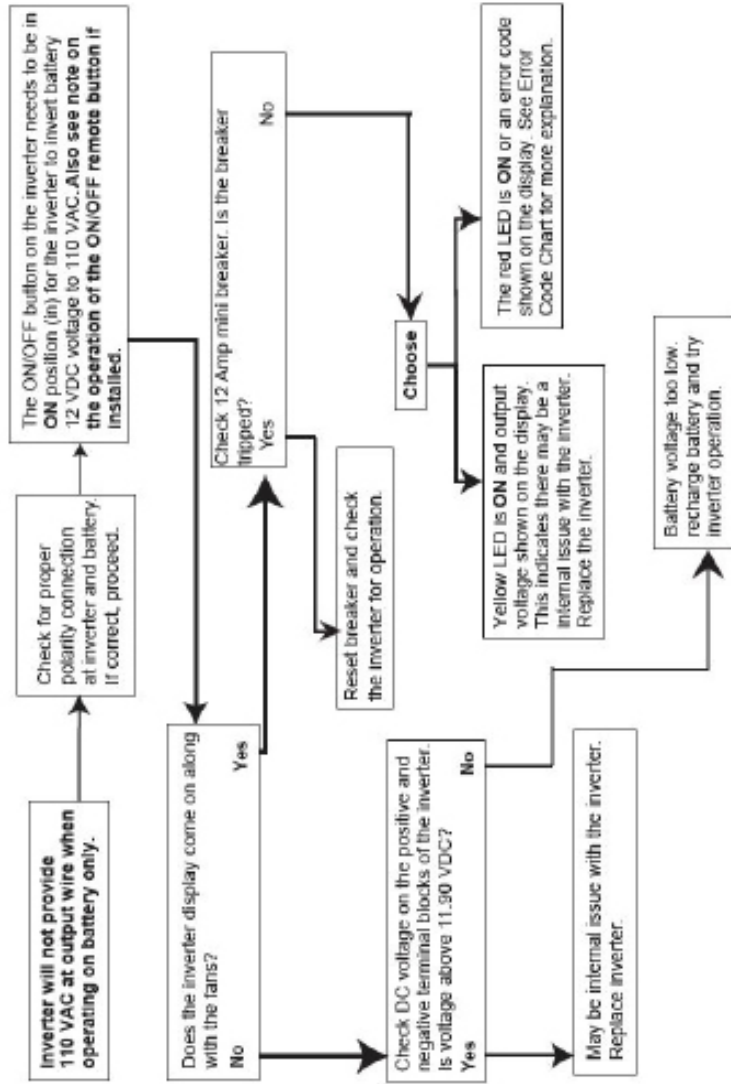

GENERAL COMPLIANCE INFORMATION

Agency Listings

UL

The WF-5118/5120 Inverter units are UL-Listed, and cUL-Listed (Canadian).

FCC Compliance Class B

NOTE: This equipment has been tested and found to comply with the limits for a Class B digital device, pursuant to Part 15 of the FCC Rules. These limits are designed to provide reasonable protection against harmful interference when the equipment is operated in a commercial environment. This equipment generates, uses, and can radiate radio frequency energy, and if not installed and used in accordance with the instruction manual, may cause harmful interference to radio communications. Operation of this equipment in a residential area is likely to cause harmful interference in which case the user will be required to correct the interference at his own expense.

INSTALLATION INSTRUCTIONS

Installing the WF-5118/5120 Inverters

Mounting the Enclosure

The WF-5118/5120 Inverters enclosure should be mounted near the house battery in an accessible area such as a wall or in the side of a cabinet. The front of the enclosure should not be obstructed to allow free air flow for the cooling fans and to allow access to the front panel controls. The WF-5118 and WF-5120 enclosures need a mounting area of 16.2”L x 10.8”W x 6.65”H.



! W A R N I N G !

Shock Hazard. Before proceeding with installation, carefully check to see if the Inverter is connected to the batteries, and any electrical source wiring is disconnected. Do not connect the inverter output to any AC source.

AC Ground Bonding

During AC wiring installation, the AC input and output grounds are connected to the inverter. The AC input ground wire must be connected to the incoming ground wire of the AC utility source. The AC output ground wire should be connected to the grounding point for your loads; for example, a distribution panel ground bar.

Neutral Grounding

The neutral conductor of the AC output circuit of the inverter is automatically connected to the safety ground during inverter operation. This conforms to National Electrical Code requirements that a derived AC source, such as an inverter or generator, must have their neutral conductors tied to ground in the same way that the neutral conductor from the utility is tied to ground at the AC breaker panel. When AC utility power is present and the inverter is in bypass mode, this neutral to ground connection is not present. The utility power neutral is only connected to ground at the breaker panel.

AC System Wiring

The AC Pass-Through and AC output wiring location is on the lower left side of the rear panel. Both input and output connections should be made at the same time. Connections to the WF-5118 Inverter should be made using 12 AWG Romex wire. Connections to the WF-5120 Inverter must be made using 10 AWG Romex wire.

Begin cable installation by backing out the knurled screw on the wiring inspection panel. Remove and set aside the screws that hold the AC input and AC output cable connectors in place. Remove the clamp plates. Open the clamps by backing out the clamp screws to widen the opening.

Making AC Input (Pass-Through) Connections on the WF-5118 Inverter

1. Insert approximately 4" of one end of a 12 AWG Romex wire through the clamp on the AC input plate and tighten the clamp screws to secure the cable. The other end of this cable attaches to a circuit breaker in the power panel.
2. Remove approximately 3 ½" of outer sheathing from the wire.
3. Separate the wires and strip ¾" of insulation from the White and Black wires.
4. Locate the AC input wires inside the WF-5118 Inverter wiring box. Connect the Romex wires to the inverter output wires using listed wiring connectors. Wire Black to Black, White to White, and Ground to Green. Make sure connections are secure.
5. Fold the connected wires back into the wiring box.
6. Reattach the clamp plate to the inverter and secure with the screw.

Making AC Output Connections on the WF-5118 Inverter

1. Insert approximately 4" of one end of a 12 AWG Romex wire through the clamp on the AC output plate and tighten the clamp screws to secure the cable. The opposite end of this cable attaches to the load circuit.
2. Remove approximately 3 ½" of outer sheathing from the wire.
3. Separate the wires and strip ¾" of insulation from the White and Black wires.
4. Locate the AC output wires inside the WF-5118 Inverter wiring box. Connect the Romex wires to the inverter output wires using listed wiring connectors. Wire Black to Black, White to White, and Ground to Green. Make sure connections are secure.
5. Fold the connected wires back into the wiring box.
6. Reattach the clamp plate to the inverter and secure with the screw.

Push all the wires back into the wiring box and fasten the inspection plate back in place with the knurled screw.

Making AC Connections on the WF-5120 Inverter

To make AC input/output connections on the WF-5120 Inverter, follow steps 1 through 6 above, but use 10 AWG wire in place of the 12 AWG wire.

DC Wiring Connections

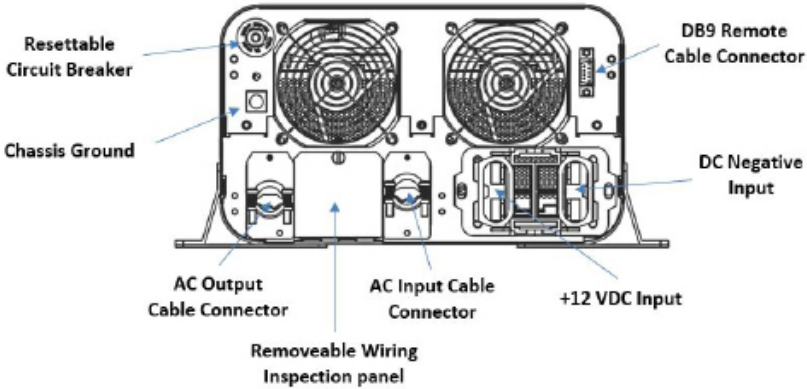

!WARNING!

A fuse or circuit breaker must be installed in the Positive wire from the battery going to the Positive lug on the WF-5118/5120 Inverter. Failure to add this in-line protection may cause damage to the inverter and void the warranty.

A fuse is required by the National Electrical Code (NEC) to protect the battery and cables. A UL listed 250 Amp DC rated slow blow fuse or circuit breaker must be installed in the Positive battery cable within 18 inches of the battery.

The DC connecting cables should be made of copper wire. To achieve maximum battery voltage at the WF-5118/5120 Inverter terminals, keep the cable lengths as short as possible. The WF-5118/5120 require 2/0 AWG wires for DC connections.

If not already available, prepare a Red Positive 2/0 AWG battery cable by stripping back ½" of insulation and crimping on a 3/8" ring terminal. In a similar fashion, prepare a Black Negative battery cable.

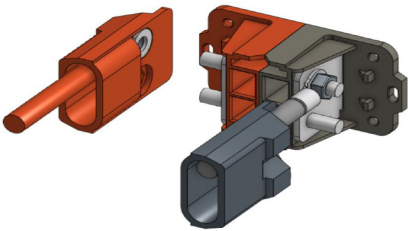

+12 VDC Input

Using a 14mm wrench, remove one of the two Positive (Red) lug nuts from the Red DC power block on the inverter's rear panel. Route the Red Positive battery cable through the Red flexible lug insulator and attach it to the Positive battery lug on the inverter. Torque this lug to 45 in-lbs. *NOTE: Using the proper torque to secure this connection is important. A loose connection can cause inverter performance issues and may lead to excessive heat build-up and damage to the unit.* Slip the insulator over the lug ends and press to secure in place.

DC Negative Input

Using a 14mm wrench, remove one of the two Negative (Black) lug nuts from the Black DC power block on the inverter's rear panel. Route the Black Negative battery cable through the Black flexible lug insulator and attach it to the Negative battery lug on the inverter. Torque this lug to 45 in-lbs. *NOTE: Using the proper torque to secure this connection is important. A loose connection can cause inverter performance issues and may lead to excessive heat build-up and damage to the unit.* Slip the insulator over the lug ends and press to secure in place.

Other Connections

Chassis Ground

Using a 5/32" hex wrench, loosen the Ground lug screw located on the mid left side of the rear panel. Insert an 8AWG copper wire from this lug to chassis ground. Tighten the lug securely.

Remote Switch Cable

The Remote switch is an optional device that is included with the WF-5118 and WF-5120 Inverters. If remote operation of the WF-5118/5120 Inverter is desired, mount the Remote switch within 32.8' of the inverters rear panel. Using a 2 1/4" hole saw, make a cutout in the cabinet or wall where the switch is to be located.

Using the supplied connecting cable, attach the DB9 connector to the DB9 connector on the right side of the inverter's rear panel. Route the cable through the RV to the Remote switch mounting location. Plug the 10-position single row connector into the back of the Remote switch. Attach the switch to the cabinet or wall with 4 screws (not supplied).

SPECIFICATIONS

Model and Ratings:		
Model:	WF-5118	WF-5120
Output Power	1.8 kW, 15 A Continuous	2.0 kW, 16.7 A Continuous
AC Output Voltage	120V/60Hz	
DC Input	12 VDC (Nominal), 180 A. Cont.	12VDC (Nominal), 200 A. Cont.
AC Pass-Through	120 VAC/60 Hz., 18 A. Max.	120 VAC/60 Hz., 25 A. Max.
Inverter power:		
Input voltage:	12V VDC (Nominal)	
Input voltage range:	10 - 15 VDC	
Low battery reminding:	11 VDC	
Low battery cutoff:	10 VDC	
AC Voltage Regulation:	± 3% from no load to full load under battery range	
Output THD:	Pure sine-wave; resistive load < 3%	
Output Crest Factor:	> 3, accepting 3 times surge (peak) inrush current	
Standby Current:	< 8.6 ADC	
Control:		
Power On/off	Push Switch (latching type)	
Transfer Switch:	Automatically transfer to battery power whenever AC power fails DPDT relay with 20A/120 VAC contact rating	
Transfer Time:	< 50 milliseconds	
Display		
LED Display:	Green - AC Pass-Through; Amber - Operating on Battery; Red - Overload Two LED Bars (with 4 LEDs) - Battery & Load level	
Remote Panel		
Power On/off	Push Switch (latching type)	
Remote Display	Same as the display on the unit panel	
Wiring cable	32.8-foot (10 meters) cable	
Protection:		
Overload & short-circuit:	Current-limiting upon overload; system shutdown upon short-circuit	
DC Reverse Polarity:	Battery reverse Input protected by fuse	
Over temperature:	System shut down	
AC Output Power:	Protected by 20A/120VAC Circuit Breaker	
Internal Cooling:	DC brushless forced fans	
AC Connection:	Terminal board hard-wiring for AC input and output	
DC Connection:	# 2/0 AWG wires required and with 250 ADC in-line fuse	
Mechanical:		
Dimension: L x H x W	412 x 274 x 169 mm / 16.2 x 10.8 x 6.65 inches	
Packing Dimension:	485 x 380 x 265 mm / 19.1 x 15 x 10.4 inches	
Weight	Net: 9.08 Kgs / 20 lbs; Gross: 10.9 kgs / 24 lbs	
Environmental:	32 - 104°F / 0 - 40°C / 20 - 90% Non-condensing	
Safety	cUL458; EMC - FCC Class B compliance	

CONSUMER LIMITED WARRANTY for WFCO Electronic Products

WFCO extends, to the original owner, a Two Year Limited Product Warranty. This warranty is in effect from the date of original purchase for a period of two (2) years. This limited warranty is extended specifically for and is limited to Recreational Vehicle application and is only valid within the continental United States, Alaska, Hawaii and the Provinces of Canada.

WFCO warrants, to the owner, that its products are free from defects in material and workmanship under normal use and service based on its intended use and function. This warranty is limited to the repair or replacement, at WFCO's discretion, of any defective parts or defective assembly. Any implied warranties of merchantability or fitness for intended use are limited in duration unless applicable State Law provides otherwise. You may have other rights as specified by each individual state.

EXCLUSIONS and LIMITATIONS

The OEM warranty specifically does not apply to the following:

- Any WFCO product that has been repaired or altered by an unauthorized person;
- Any damage caused by misuse, faulty installation, testing, negligence, accident or any WFCO product installed in a commercial vehicle;
- Any WFCO product, whose serial number has been defaced, altered or removed;
- Any WFCO product, whose installation has not been in accordance to the WFCO written instructions;
- Any consequential damages arising from the loss of use of the product including but not limited to: inconvenience, loss of service, loss of revenue, loss or damage to personal property, cost of all services performed in removing or replacing the WFCO product. Specifications are subject to change without notice or obligation.
- Any WFCO Technologies' products sold through unauthorized Internet sources (Example: eBay) will be excluded from all warranty coverage offered by WFCO.

CONSUMER WARRANTY CLAIM PROCEDURE

Upon determination and validation by an authorized OEM dealer that a WFCO product has a defect, a Return Goods Authorization (RGA) number will be required before the product can be returned. The RGA number can be requested by completing the Warranty Information Fax Sheet and appropriate Troubleshooting Form found at www.wfcoelectronics.com. Once these forms have been completed, email the forms along with Proof of Purchase to warranty@wfcoelectronics.com or fax the three documents to the Warranty Department at (574) 294-8698. After receipt of the forms, an RGA number will be issued. This number shall appear on all correspondence with warranty service. Upon validation of the warranty, WFCO shall replace the product with a like product. The RGA number shall be placed on the outside of the carton used to return the product for ease of identification. Do not mark directly on the product. The product must be packaged properly to avoid further product damage which could cause a non-warrantable condition.

WARRANTY ASSISTANCE

The consumer may contact the selling Dealer or OEM for warranty assistance. The consumer may also contact **WFCO Technologies, at: (574) 294-8997 or Fax (574) 294-8698.**



DIMENSIONAL DRAWING

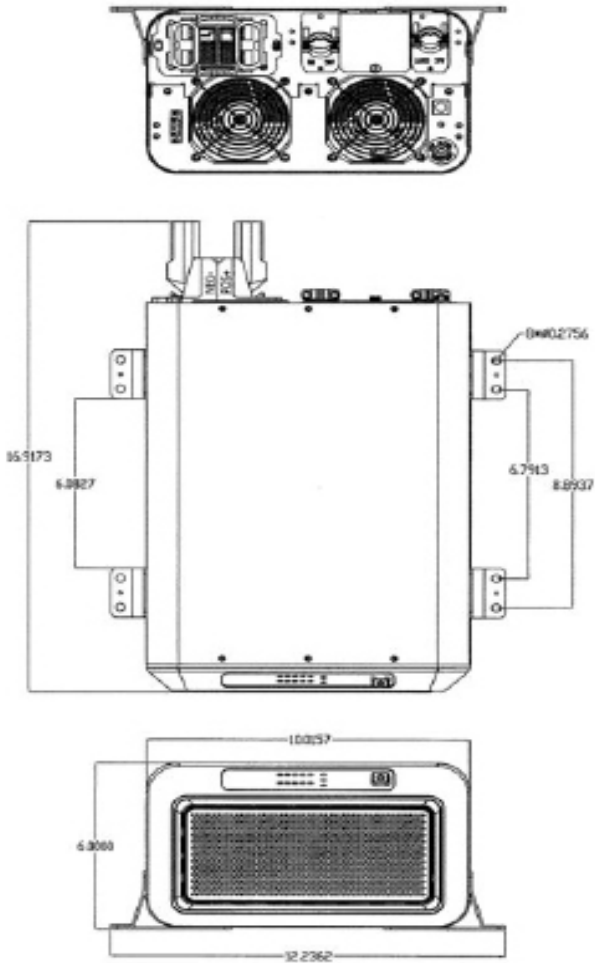



**2021 Aeroplex Drive, North
Elkhart, IN 46514
574-294-8997
www.wfcotech.com**



EXPERT PRODUCT SUPPORT

Power Pros Technical Support
(574) 294-8997, Option 1
technicalsupport@wfcocoelectronics.com

Warranty Information
Fax: (574) 294-8698
warranty@wfcocoelectronics.com